

A2970

SERVICE PARTS LIST

THE M.G. Series MGA TWIN CAM

Item No.	DESCRIPTION	Commencing (C) 501		Qty. per Vehicle		Unit of Issue	Type of Vehicle	MODIFICATIONS			REMARKS
		Part Number	Illus. No.	RHD	LHD			New Part Number	Change Point	Amdt. No.	
	BRAKE CONTROLS										
1	Pedal—brake	AHH5693	M1	1							
2	Pedal—brake	AHH5695			1						
3	Bush	185794	M2	1	1						
4	Pad—pedal (rubber)	AHH5100	M3	1	1						
5	Distance piece—pedal	185795	M4	2	2						
6	Distance washer—pedal	AHH5728	M5	1	1						
7	Bolt—pedal to bracket	HBZ0628	M6	1	1						
8	Nut for bolt	FNZ106	M7	1	1						
9	Washer for nut (spring)	LWZ206	M8	1	1						
10	Distance tube—pedal stop	AHH5692	M9	1	1						
11	Rod—distance tube	AHH5752	M10	1	1						
12	Nut for rod	FNZ104	M11	2	2						
13	Washer for nut (spring)	LWZ204	M12	2	2	12					
14	Clevis pin—brake pedal	CLZ0515	M13	1	1						
15	Washer for pin (plain)	PWZ105	M14	1	1						
16	Spring—pedal pull-off	130154	M15	1	1	6					
17	Fume excluder—pedal	AHH5689	M16	1	1						
18	Cover-plate—fume excluder	AHH5688	M17	1	1						
19	Base plate assembly—box	AHH5687	M18	1	1						
20	Screw—plate to cross-bar	HPZ0506	M19	2	2						
21	Washer for screw (spring)	LWZ205	M20	2	2	24					
22	Screw—cover-plate to base plate	HZS0506	M21	2	2						
23	Nut for screw	FNZ105	M22	2	2						
24	Washer for nut (spring)	LWZ205	M23	2	2	24					
25	Support bracket—R.H.	AHH5691	M24	1	1						
26	Support bracket—L.H.	AHH5690	M25	1	1						
27	Screw—bracket to tapping plate	HZS0505	M26	4	4						
28	Washer for screw (spring)	LWZ205	M27	4	4	24					
29	Box—master cylinder	AHH5684	M28	1	1						
30	Screw—box to bulkhead	HZS0506	M29	2	2			AHH5877	Com. (C) 997		
31	Nut for screw	FNZ105	M30	2	2						
32	Washer for nut (plain)	PWZ205	M31	2	2						
33	Washer for nut (spring)	LWZ205	M32	2	2	24					
34	Screw—box to bracket	HZS0506	M33	6	6						
35	Nut for screw	FNZ105	M34	6	6						
36	Washer for nut (spring)	LWZ205	M35	6	6	24					
37	Reinforcement piece—box	AHH5685	M36	1	1			AHH5876	Com. (C) 997		
38	Blanking plate	AHH5753	M37	1	1						
39	Seal—blanking plate (rubber)	AHH5754	M38	1	1						
40	Screw fixing blanking plate	HPZ0508	M39	2	2						
41	Screw fixing blanking plate	HZS0506	M40	2	2						
42	Nut for screw	FNZ105	M41	2	2						
43	Washer for screw (spring)	LWZ205	M42	4	4	24					

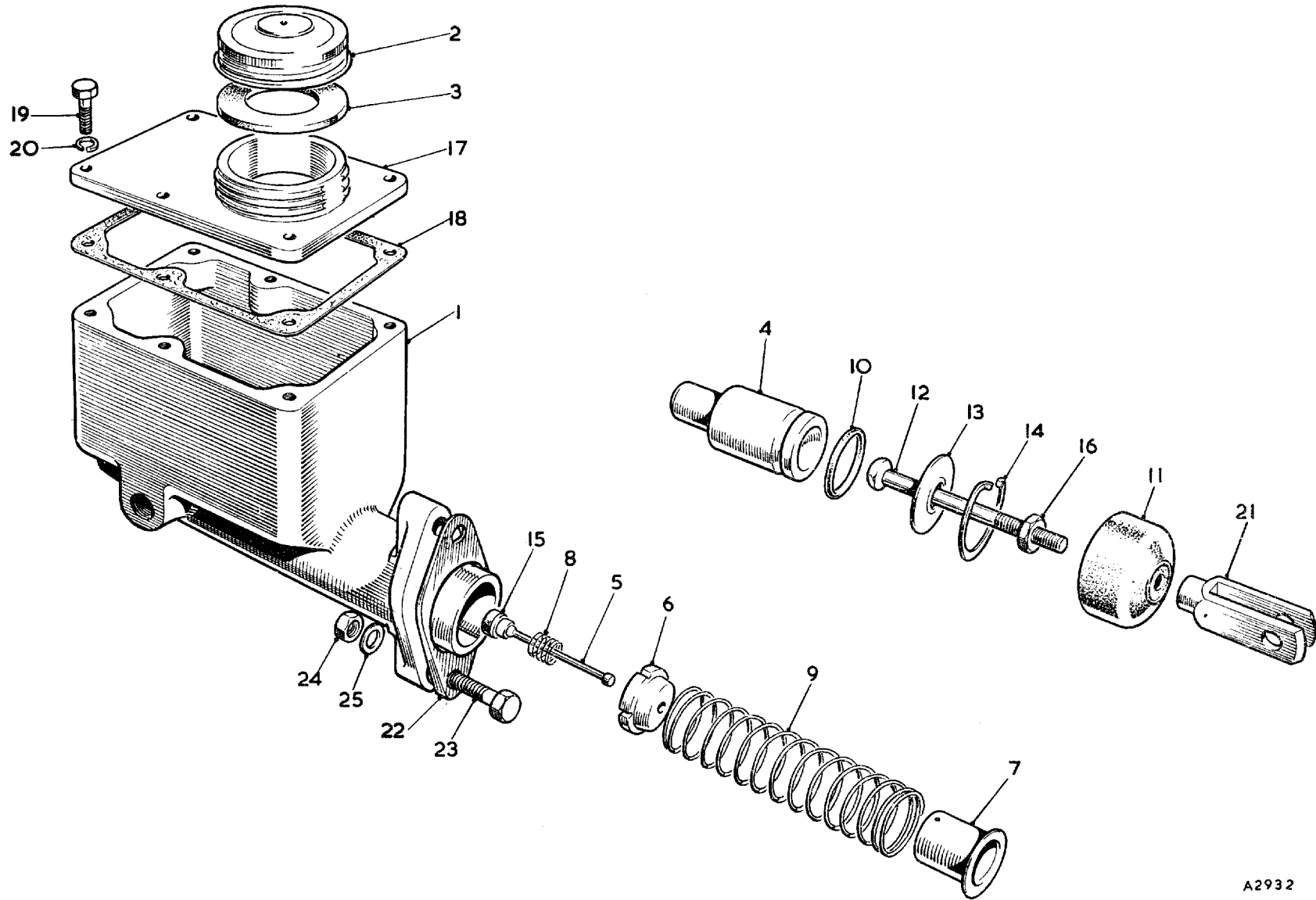

A2932

SERVICE PARTS LIST

THE M.G. Series MGA TWIN CAM

Item No.	DESCRIPTION	Commencing (C) 501		Qty. per Vehicle		Unit of Issue	Type of Vehicle	MODIFICATIONS			
		Part Number	Illus. No.	RHD	LHD			New Part Number	Change Point	Amdt. No.	REMARKS
	BRAKE MASTER CYLINDER										
1	Cylinder and supply tank assembly	BHA4071		1	1						
2	Body	N.S.P.	MA1	1	1						
3	Cap	7H8223	MA2	1	1						
4	Washer for cap	7H8224	MA3	1	1						
5	Piston	7H8225	MA4	1	1						
6	Valve	7H8226	MA5	1	1						
7	Spring support—rear end	7H8227	MA6	1	1						
8	Spring support—front end	7H8228	MA7	1	1						
9	Spring—valve	7H8229	MA8	1	1						
10	Spring—main	7H8230	MA9	1	1						
11	Seal—piston	7H8236	MA10	1	1						
12	Dust excluder	7H8237	MA11	1	1						
13	Push-rod	7H8231	MA12	1	1						
14	Washer	7H8232	MA13	1	1						
15	Circlip	7H8233	MA14	1	1						
16	Rubber seal and bush	7H8238	MA15	1	1						
17	Locknut for push-rod	FNZ205	MA16	1	1						
18	Cover	N.S.P.	MA17	1	1						
19	Gasket	7H8235	MA18	1	1						
20	Screw	AJD1021	MA19	6	6						
21	Washer (spring)	AJD7612	MA20	6	6						
22	Grease for rubber	7H8234		1	1						
23	Service kit for master cylinder	8G8196		1	1						
24	Seal—piston			1	1						
25	Dust excluder			1	1						
26	Rubber seal and bush			1	1						
27	Grease for rubber			1	1						
28	Fork end	FEZ105	MA21	1	1						
29	Taper packing—master cylinder	AHH5874	MA22	2	2						
30	Bolt fixing master cylinder	HZS0513	MA23	2	2			HZS0510	Fin. (C) 996 Com. (C) 997		
31	Nut for bolt	LNZ205	MA24	2	2						
32	Washer for nut (plain)	PWZ105	MA25	2	2						

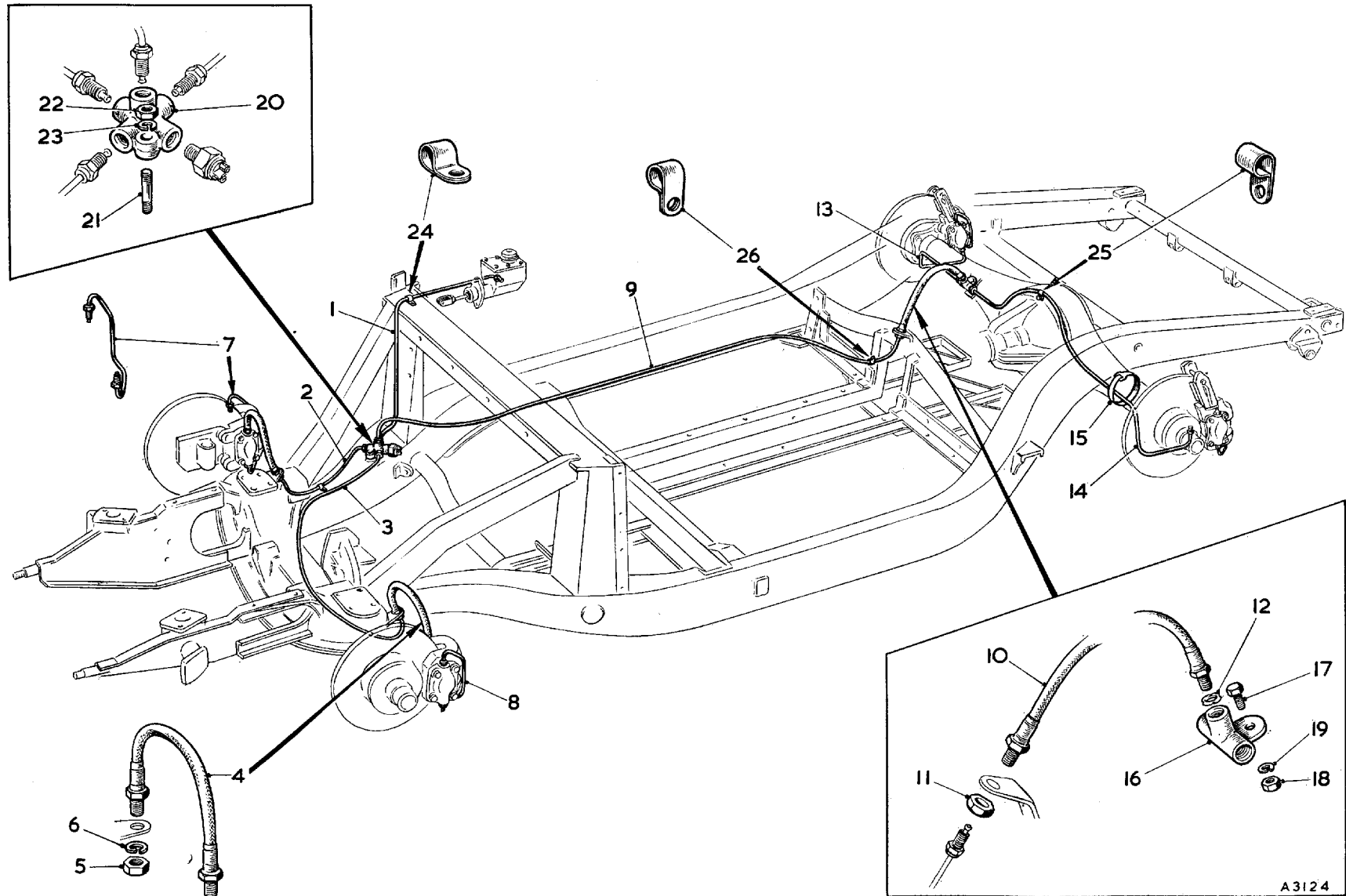

SERVICE PARTS LIST

THE M.G. Series MGA TWIN CAM

Item No.	DESCRIPTION	Commencing (C) 501		Qty. per Vehicle		Unit of Issue	Type of Vehicle	MODIFICATIONS			REMARKS
		Part Number	Illus. No.	RHD	LHD			New Part Number	Change Point	Amdt. No.	
	HYDRAULIC PIPES AND FITTINGS										
1	Pipe—master cylinder to 5-way connection (29")	AHH5769	MB1	1							
2	Pipe—master cylinder to 5-way connection (49½")	AHH5770			1						
3	Pipe—5-way connection to R.H. front hose (17¼")	AHH5763	MB2	1	1						
4	Pipe—5-way connection to L.H. front hose (43¼")	AHH5764	MB3	1	1						
5	Hose—front	AHH5773	MB4	2	2						
6	Locknut—hose	FNZ206	MB5	4	4						
7	Washer for locknut (spring)	LWZ206	MB6	4	4						
8	Bridge pipe—front hose to brake R.H.	AHH5806	MB7	1	1						
9	Bridge pipe—front hose to brake L.H.	AHH5807	MB8	1	1						
10	Pipe—5-way connection to rear hose (79½")	AHH5768	MB9	1	1						
11	Hose—rear	AHH5774	MB10	1	1						
12	Locknut—hose	2K8686	MB11	1	1						
13	Washer for locknut (shakeproof)	LWZ210		1	1						
14	Gasket—rear hose to 3-way	3H2237	MB12	1	1						
15	Pipe—3-way connection to rear brake R.H. (17¼")	AHH5766	MB13	1	1						
16	Pipe—3-way connection to rear brake L.H. (45")	AHH5767	MB14	1	1						
17	Strap—brake pipe to axle	ACH8650	MB15	1	1						
18	3-way connection	AHH5772	MB16	1	1						
19	Screw—3-way connection and cable clip to axle	HZS0506	MB17	1	1						
20	Nut for screw	FNZ105	MB18	1	1						
21	Washer for nut (spring)	LWZ205	MB19	1	1	24					
22	5-way connection	AHH5771	MB20	1	1						
23	Stud for 5-way connection	AHH5875	MB21	1	1						
24	Nut for stud	FNZ104	MB22	1	1						
25	Washer for nut (spring)	LWZ204	MB23	1	1	12					
26	Clip—brake pipe to master cylinder base plate	PCR0311	MB24	1							
27	Clip—brake pipe to bulkhead	PCR0311			2						
28	Clip—brake pipe to differential case bolt	PCR0311	MB25	1	1						
29	Clip—brake pipe to battery carrier	PCR0307	MB26	1	1						

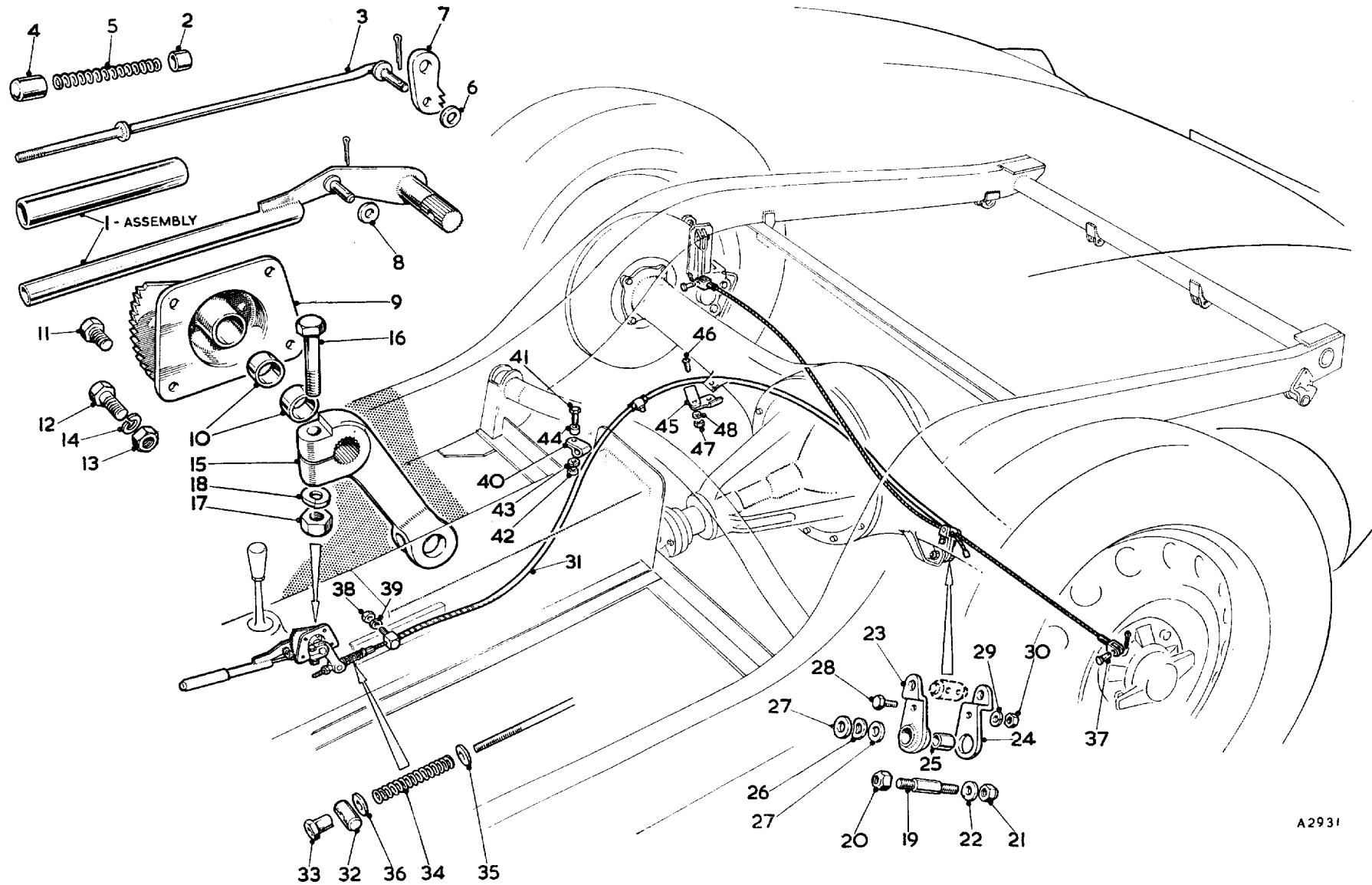

A2931

SERVICE PARTS LIST

THE M.G. Series MGA TWIN CAM

Item No.	DESCRIPTION	Commencing (C) 501		Qty. per Vehicle		Unit of Issue	Type of Vehicle	MODIFICATIONS			REMARKS
		Part Number	Illus. No.	RHD	LHD			New Part Number	Change Point	Amdt. No.	
	HAND BRAKE MECHANISM										
1	Hand brake assembly	AHH5229		1	1						
2	Handle plate and shaft assembly	AHH5230	MC1	1	1						
3	Bush—handle plate and shaft	81756	MC2	1	1						
4	Rod assembly—pawl	AHH5233	MC3	1	1						
5	Knob—pawl rod	ACC8956	MC4	1	1						
6	Spring—pawl rod	80641	MC5	1	1						
7	Washer (plain)	PWZ103	MC6	1	1						
8	Pawl	AHH5238	MC7	1	1						
9	Washer (plain)	PWZ105	MC8	1	1						
10	Fulcrum and ratchet assembly	AHH5232	MC9	1	1						
11	Bush	AHH5242	MC10	2	2						
12	Screw—hand brake to gearbox cover	HZS0504	MC11	5	5						
13	Screw—hand brake to gearbox cover	HZS0505	MC12	3	3						
14	Nut for screw	FNZ105	MC13	8	8						
15	Washer for screw (spring)	LWZ205	MC14	8	8	24					
16	Lever—hand brake operating	AHH5244	MC15	1	1						
17	Bolt for operating lever	HBZ0510	MC16	1	1						
18	Nut for bolt	FNZ105	MC17	1	1						
19	Washer for bolt (spring)	LWZ205	MC18	1	1	24					
20	Fulcrum—hand brake compensator	AHH5025	MC19	1	1						
21	Nut for fulcrum to axle	LNZ106	MC20	1	1						
22	Nut for compensator to fulcrum	LNZ105	MC21	1	1						
23	Washer for compensator to fulcrum (plain)	PWZ205	MC22	1	1						
24	Lever—inner compensating	AHH5203	MC23	1	1						
25	Lever—outer compensating	ACH5101	MC24	1	1						
26	Bush—compensating lever	AHH5225	MC25	1	1						
27	Washer for compensating lever (anti-rattle)	AHH5224	MC26	1	1						
28	Washer for compensating lever (plain)	PWZ107	MC27	2	2						
29	Screw for compensating lever	HZS0405	MC28	1	1						
30	Washer for screw (spring)	LWZ204	MC29	1	1	12					
31	Nut for screw	FNZ104	MC30	1	1						
32	Cable—hand brake	AHH5761	MC31	1	1						
33	Trunnion—cable	AHH5322	MC32	1	1						
34	Nut—adjuster	ACH5104	MC33	1	1						
35	Spring—cable	ACH8508	MC34	1	1						
36	Washer for cable spring—rear (plain)	PWZ104	MC35	1	1	12					
37	Washer for cable spring—front (plain)	PWZ204	MC36	1	1						
38	Clevis pin	ACB8715	MC37	2	2						

SERVICE PARTS LIST

THE M.G. Series MGA TWIN CAM

Item No.	DESCRIPTION	Commencing (C) 501		Qty. per Vehicle		Unit of Issue	Type of Vehicle	MODIFICATIONS			REMARKS
		Part Number	Illus. No.	RHD	LHD			New Part Number	Change Point	Amdt. No.	
	Hand Brake Mechanism—continued										
1	Nut—abutment	FNZ105	MC38	1	1						
2	Washer for nut (spring)	LWZ205	MC39	1	1	24					
3	Clip—cable to battery carrier	PCR0507	MC40	1	1						
4	Screw—cable and main pipe clips to battery carrier	PMZ0316	MC41	1	1						
5	Nut for screw	FNZ103	MC42	1	1						
6	Washer for nut (spring)	LWZ203	MC43	1	1						
7	Distance tube for battery carrier clip	AHH5297	MC44	1	1						
8	Clip—cable to axle bracket	AHH5295	MC45	1	1						
9	Screw for clip	PMZ0806	MC46	1	1						
10	Nut for screw	FNZ103	MC47	1	1						
11	Washer for nut	LWZ203	MC48	1	1						

