

SECTION N

ELECTRICAL EQUIPMENT

General description.

- Section No. N.1 Battery maintenance.
- Section No. N.2 Dynamo.
- Section No. N.3 Removing and replacing the dynamo.
- Section No. N.4 Dismantling the dynamo.
- Section No. N.5 Servicing the dynamo.
- Section No. N.6 Starter.
- Section No. N.7 Removing and replacing the starter.
- Section No. N.8 Servicing the starter.
- Section No. N.9 Control box.
- Section No. N.10 Fuses.
- Section No. N.11 Electric horn.
- Section No. N.12 Flashing direction indicators.
- Section No. N.13 Windshield wiper.
- Sections Nos. N.14 to N.24 Lamps.
- Section No. N.25 Replacement bulbs.
- Section No. N.26 Fitting a fog lamp.
- Section No. N.27 Location and remedy of faults.
- Section No. N.28 Windowless yoke dynamo.
- Section No. N.29 Modified control box.
- Section No. N.30 Headlamp beam setting.
- Section No. N.31 Dry-charged batteries.
- Section No. N.32 Modified European light unit

GENERAL DESCRIPTION

The 12-volt electrical equipment incorporates compensated voltage control for the charging circuit. The positive earth system of wiring is employed.

The two 6-volt batteries, mounted to the rear of the seats, are accessible for examination and maintenance attention.

The dynamo is mounted on the right of the cylinder block and driven by endless belt from the engine crankshaft. A rotatable mounting enables the belt tension to be adjusted.

The control box is sealed and should not normally need attention. The fuses and spare fuses are carried in external holders.

The starter motor is mounted on the flywheel housing on the right-hand side of the engine unit and operates on the flywheel through the usual sliding pinion device.

The headlamps employ the double-filament dipping system. Both lamps dip according to the regulations existing in the country concerned.

Section N.1**BATTERY MAINTENANCE**

In order to keep the batteries in good condition, a periodical inspection must be made.

Unscrew the five quick-release fasteners securing the panel immediately behind the seats and lift the panel away to obtain access to the batteries.

Topping up

Weekly, remove the filler plug from each cell and examine the level of the electrolyte. Add distilled water to bring the level of the electrolyte just above the separators.

NOTE.—Do not use tap-water and do not use a naked light when examining the condition of the cells. Wipe away all dirt and moisture from the top of the battery.

Testing the condition of the battery

Every 6,000 miles (10000 km.) examine the condition of the batteries by taking hydrometer readings. The hydrometer contains a graduated float on which is indicated the specific gravity of the acid in the cell from which the same is taken.

The specific gravity readings and their indications are as follows:

Climates below 27° C. (80° F.)

1·270 to 1·290	Cell fully charged.
1·190 to 1·210	Cell about half-discharged.
1·110 to 1·130	Cell fully discharged.

Climates frequently above 27° C. (80° F.)

1·210 to 1·230	Cell fully charged.
1·130 to 1·150	Cell about half-discharged.
1·050 to 1·070	Cell fully discharged.

These figures are given assuming an electrolyte temperature of 16° C. (60° F.). If the temperature of the electrolyte exceeds this, ·002 must be added to hydrometer readings for each 3° C. (5° F.) rise to give the true specific gravity. Similarly ·002 must be subtracted from hydrometer readings for every 3° C. (5° F.) below 16° C. (60° F.).

The readings of all the cells should be approximately the same. If one cell gives a reading very different from the rest it may be that the electrolyte has been spilled or has leaked from the cell or there may be an internal fault. Should a battery be in a low state of charge, it should be recharged by taking the car for a long daytime run or by charging from an external source of D.C. supply at a current rate of 5 amperes until the cells are gassing freely.

After examining the battery, check the vent plugs, making sure that the air passages are clear.

Storage

If a battery is to be out of use for any length of time, it should first be fully charged and then given a freshening charge about every fortnight.

A battery must never remain in a discharged condition, as the plates will become sulphated.

Initial filling and charging

When a new battery has been supplied dry it is necessary to fill the cells with electrolyte of the correct specific gravity.

All batteries, including those having type suffix letter 'Z' (e.g. SGZ, etc.) and those having no additional suffix letter (e.g. SG, BT, etc.), are assembled with dry separators. The specific gravity of the filling-in solution depends upon the climate in which the battery is to be used (i.e. 1·260 for climates below 27° C. [80° F.] and 1·210 for climates frequently above 27° C. [80° F.]). For more details of the requirements of 'dry-charged' batteries see Section N.31.

The electrolyte is prepared by mixing distilled water and concentrated sulphuric acid 1·835 S.G. The mixing must be carried out in a lead-lined tank or a suitable glass or earthenware vessel. Steel or iron containers must not be used. The acid must be added slowly to the water, while the mixture is stirred with a glass rod. **Never add the water to the acid**, as the severity of the resulting chemical reaction may have dangerous consequences.

Heat is produced by the mixture of acid and water, and it should, therefore, be allowed to cool before it is poured into the battery, otherwise the plates, separators and moulded container may be damaged.

The temperature of the filling-in acid, battery and charging room should be above 0° C. (32° F.).

To produce electrolyte of the correct specific gravity:

<i>To obtain specific gravity (corrected to 60° F. [16° C.])</i>	<i>Add 1 part by volume of 1.835 S.G. acid to distilled water by volume as below</i>
1.260	3 parts
1.210	4 parts

Carefully break the seals in the filling holes and half-fill each cell in the battery with dilute sulphuric acid solution of the appropriate specific gravity (according to temperature). The quantity of electrolyte required to half-fill a two-volt cell is $\frac{1}{2}$ pint (.28 litre). Allow to stand for at least six hours, then complete the filling of the cells by the addition of more diluted acid of the same specific gravity as before until the level reaches the bottom of the filling holes, and allow the battery to stand for at least another two hours before commencing the first charge.

Charge at a constant current of 3.5 amps. until the voltage and temperature-corrected specific gravity readings show no increase over five successive hourly readings. This period is dependent upon the length of time the battery has been stored since manufacture, and will be from 40 to 80 hours, but usually not more than 60.

Throughout the charge the acid must be kept level with the tops of the separators in each cell by the addition of electrolyte of the same specific gravity as the original filling-in acid.

If, during charge, the temperature of the acid in any cell of the battery reaches the maximum permissible temperature of 38° C. (100° F.) in a climate below 80° F. (27° C.) or 49° C. (120° F.) in a climate frequently above 80° F. (27° C.), the charge must be interrupted and the battery temperature allowed to fall at least 5.5° C. (10° F.) before charging is resumed.

At the end of the first charge, i.e. when specific gravity and voltage measurements remain constant, carefully check the specific gravity in each cell to ensure that it lies within the limits specified. If any cell requires adjustment, the electrolyte above the plates must be siphoned off and replaced either with acid of the strength used for the original filling in, or distilled water, according to whether the specific gravity is too low or too high respectively. After such adjustment, the gassing charge should be continued for one or two hours to ensure adequate mixing of the electrolyte. Re-check, if necessary, repeating the procedure until the desired result is obtained.

Section N.2

DYNAMO

To test on vehicle when dynamo is not charging

- (1) Make sure that belt slip is not the cause of the trouble. It should be possible to deflect the belt approximately $\frac{1}{2}$ in. (13 mm.) at the centre of its longest run between two pulleys with moderate hand pressure. If the belt is too slack, loosen the two dynamo suspension bolts and then the bolt of the slotted adjustment link. A gentle pull on the dynamo outwards will enable the correct tension

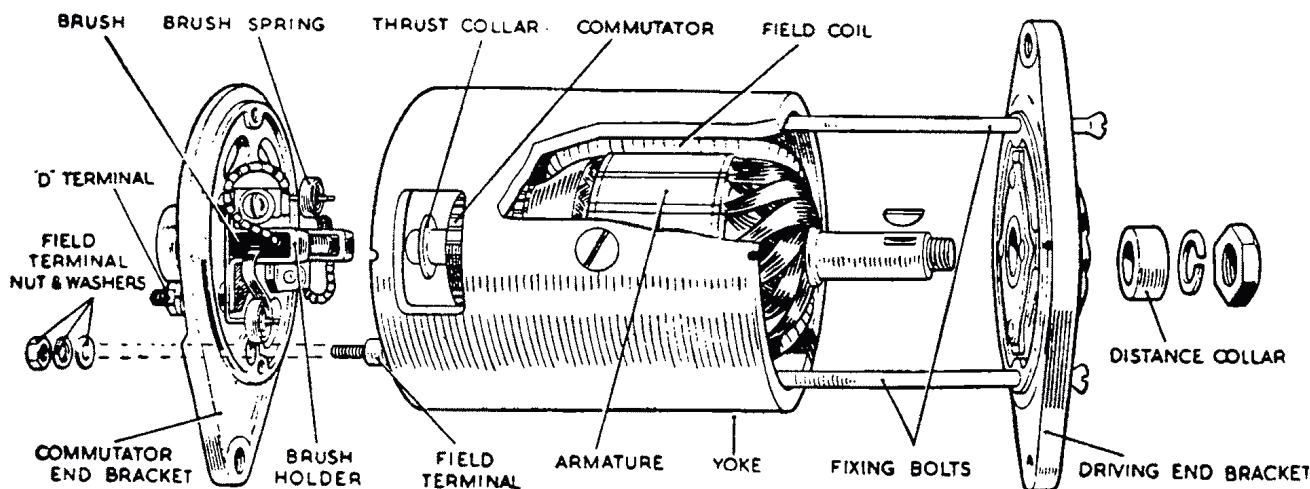

Fig. N.1

An exploded view of the dynamo

to be applied to the belt and all three bolts should then be tightened firmly.

- (2) Check that the dynamo and control box are connected correctly. The dynamo terminal 'D' should be connected to the control box terminal 'D' and the dynamo terminal 'F' connected to the control box terminal 'F'.
- (3) After switching off all lights and accessories, disconnect the cables from the dynamo terminals marked 'D' and 'F' respectively.
- (4) Connect the two terminals with a length of wire.
- (5) Start the engine and set to run at idling speed.
- (6) Clip the negative lead of a moving-coil-type voltmeter, calibrated 0-20 volts, to one dynamo terminal and the other lead to a good earthing point on the dynamo yoke.
- (7) Gradually increase the engine speed, when the voltmeter reading should rise rapidly and without fluctuation. Do not allow the voltmeter reading to reach 20 volts. Do not race the engine in an attempt to increase the voltage. It is sufficient to run the dynamo up to a speed of 1,000 r.p.m.

If there is no reading, check the brush gear.

If the reading is low (approximately 1 volt), the field winding may be faulty.

If the reading is approximately 5 volts, the armature winding may be faulty.

- (8) Remove the dynamo cover band and examine the brushes and commutator. Hold back each of the brush springs and move the brush by pulling gently on its flexible connector. If the movement is sluggish, remove the brush from its holder and ease the sides by lightly polishing on a smooth file. Always replace brushes in their original positions. If the brushes are worn so that they no longer bear on the commutator, or if the brush flexible lead has become exposed on the running face, new brushes must be fitted. If the commutator is blackened or dirty, clean it by holding a petrol-moistened cloth against it while the engine is turned slowly by hand-cranking. Re-test the dynamo; if there is still no reading on the voltmeter there is an internal fault and the complete unit should be renewed.

If the dynamo is in good order, leave the temporary link in position between the terminals and restore the original connections, taking care to connect the dynamo terminal 'D' to the control box terminal 'D' and the dynamo terminal 'F' to the control box terminal 'F'. Remove the lead from the 'D' terminal on the control box and connect the voltmeter between this cable and a good earthing point on the vehicle. Run the engine

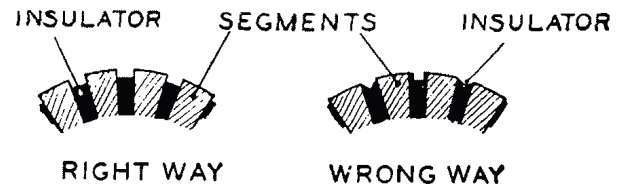

Fig. N.2

The correct method of undercutting the dynamo commutator

as before. The reading should be the same as that measured directly at the dynamo. No reading on the voltmeter indicates a break in the cable to the dynamo. Carry out the same procedure for the 'F' terminal, connecting the voltmeter between cable and earth. Finally remove the link from the dynamo. If the reading is correct test the control box (Section N.9).

Section N.3

REMOVING AND REPLACING THE DYNAMO

To remove the dynamo, disconnect the dynamo leads from the dynamo terminals.

Slacken all four attachment bolts and pivot the dynamo towards the cylinder block to enable the fan belt to be removed from the dynamo pulley. The dynamo can then be removed by completely removing the two upper and one lower attachment bolts.

Replacement of the dynamo is an exact reversal of this procedure.

Section N.4

DISMANTLING THE DYNAMO

Take off the dynamo pulley.

Remove the cover band, hold back the brush springs and remove the brushes from their holders.

Unscrew the locknuts from the through-bolts at the commutator end. Withdraw the two through-bolts from the driving end.

Remove the nut, spring washer and flat washer from the smaller terminal (i.e. field terminal) on the commutator end bracket and remove the bracket from the dynamo yoke.

The driving end bracket, together with the armature, can now be lifted out of the yoke.

The driving end bracket which, on removal from the yoke, has withdrawn with it the armature and armature shaft ball bearing, need not be separated from the shaft unless the bearing is suspected and requires examination, in which event the armature should be removed from the end bracket by means of a hand press.

Section N.5

SERVICING THE DYNAMO

Brushes

Test if the brushes are sticking. Clean them with petrol and, if necessary, ease the sides by lightly polishing with a smooth file. Replace the brushes in their original positions.

Test the brush spring tension with a spring scale if available. The correct tension is 20–5 oz. (567–709 gm.). Fit a new spring if the tension is low.

If the brushes are worn so that the flexible lead is exposed on the running face, new brushes *must* be fitted. Brushes are pre-formed so that bedding to the commutator is unnecessary.

Commutator

A commutator in good condition will be smooth and free from pits or burned spots. Clean the commutator with a petrol-moistened cloth. If this is ineffective, carefully polish with a strip of fine glass-paper while rotating the armature. To remedy a badly worn commutator, mount the armature (with or without the drive end bracket) in a lathe, rotate at high speed and take a light cut with a very sharp tool. Do not remove more metal than is necessary. Polish the commutator with very fine glass-paper. Undercut the mica insulation between the segments to a depth of $\frac{1}{32}$ in. (.8 mm.) with a hacksaw blade ground down to the thickness of the mica.

Field coils

Test the field coils, without removing them from the dynamo yoke, by means of an ohmmeter. The reading on the ohmmeter should be between 6.0 and 6.3 ohms. If this is not available, connect a 12-volt D.C. supply with an ammeter in series between the field terminal and the dynamo yoke. The ammeter reading should be approximately 2 amps. If no reading is indicated the field coils are open-circuited and must be renewed. To test for earthed field coils, unsolder the end of the field winding from the earth terminal on the dynamo yoke and, with a test lamp connected from supply mains, test across the field terminal and earth. If the lamp lights, the field coils are earthed and must be renewed.

When fitting field coils, carry out the procedure outlined below, using an expander and wheel-operated screwdriver:

- (a) Remove the insulation piece which is provided to prevent the junction of the field coils from contacting the yoke.
- (b) Mark the yoke and pole-shoes in order that they can be refitted in their original positions.

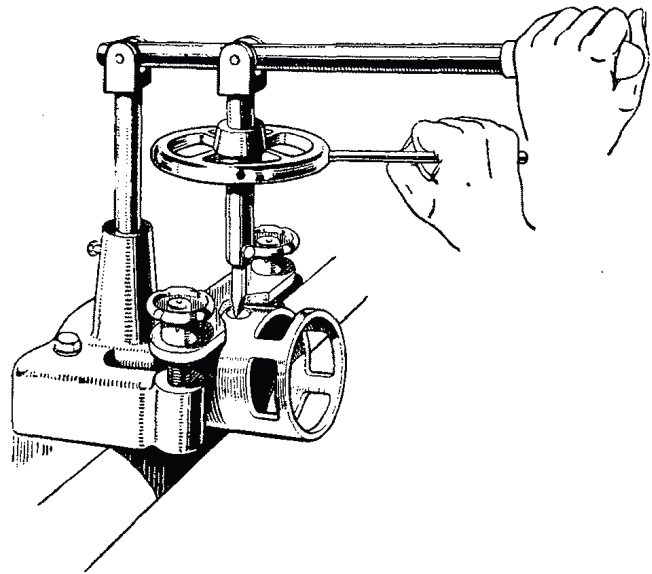

Fig. N.3

Showing the use of a wheel-operated screwdriver to remove the pole-shoe attachment screws

- (c) Unscrew the two pole-shoe retaining screws by means of the wheel-operated screwdriver.
- (d) Draw the pole-shoes and coils out of the dynamo yoke and lift off the coils.
- (e) Fit the new field coils over the pole-shoes and place them in position inside the yoke. Take care to ensure that the taping of the field coils is not trapped between the pole-shoes and the yoke.
- (f) Locate the pole-shoes and field coils by lightly tightening the fixing screw.
- (g) Insert the pole-shoe expander, open it to the fullest extent and tighten the screws.
- (h) Finally tighten the screws by means of the wheel-operated screwdriver and lock them by caulking.
- (j) Replace the insulation piece between the field coil connections and the yoke.

Armature

The testing of the armature winding requires the use of a voltage drop test and growler. If these are not available, the armature should be checked by substitution. No attempt should be made to machine the armature core or to true a distorted armature shaft.

Bearings

Bearings which are worn to such an extent that they will allow side movement of the armature shaft must be replaced by new ones.

To fit a new bearing at the commutator end of the dynamo proceed as follows:

- (a) Press the bearing bush out of the commutator end bracket.

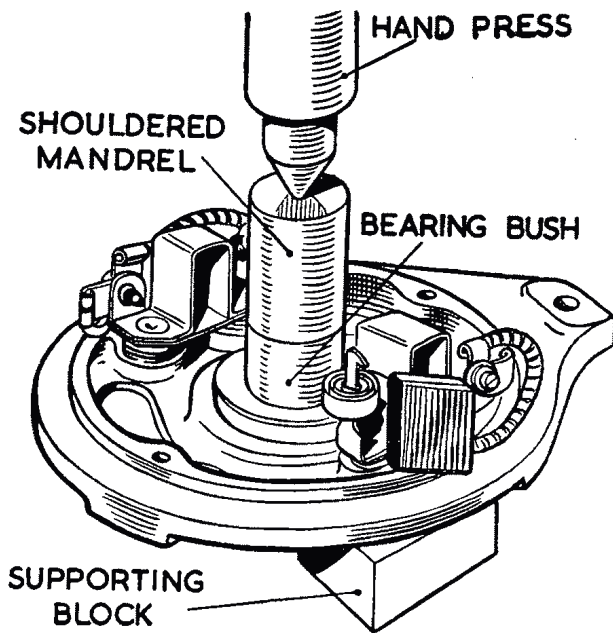

Fig. N.4

The method of pressing out the commutator end bracket bush is shown in this illustration

- (b) Press the new bearing bush into the end bracket, using a shouldered mandrel of the same diameter as the shaft which is to fit in the bearing.

Before fitting the new bearing bush allow it to stand completely immersed in thin engine oil for 24 hours, to fill the pores of the bush with lubricant.

The ball bearing at the driving end is renewed as follows:

- (a) Knock out the rivets which secure the bearing retaining plate to the end bracket and remove the plate.
- (b) Press the bearing out of the end bracket and remove the corrugated washer, felt washer and oil retaining washer.
- (c) Before fitting the replacement bearing see that it is clean and pack it with a high-melting-point grease.
- (d) Place the oil retaining washer, felt washer and corrugated washer in the bearing housing in the end bracket.
- (e) Locate the bearing in the housing and press it home by means of a hand press.
- (f) Fit the bearing retaining plate. Insert the new rivets from the inside of the end bracket and open the rivets by means of a punch to secure the plate rigidly in position.

Reassembly

The reassembly of the dynamo is a reversal of the operations described in Section N.4

If the end bracket has been removed from the armature in dismantling, press the bearing end bracket onto the armature shaft, taking care to avoid damaging the end plate and armature winding.

Add a few drops of oil through the hole in the armature end cover.

Section N.6

THE STARTER

To test on vehicle

Switch on the lamps and operate the starter control. If the lights go dim, but the starter is not heard to operate, an indication is given that current is flowing through the starter windings but that the starter pinion is meshed permanently with the geared ring on the flywheel. This was probably caused by the starter being operated while the engine was still running. In this case the starter must be removed from the engine for examination.

Should the lamps retain their full brilliance when the starter switch is operated, check that the switch is functioning. If the switch is in order, examine the connections at the battery, starter switch and starter, and also check the wiring between these units. Continued failure of the starter to operate indicates an internal fault, and the starter must be removed from the engine for examination.

Sluggish or slow action of the starter is usually caused by a poor connection in the wiring which produces a high resistance in the starter circuit. Check as described above.

Damage to the starter drive is indicated if the starter is heard to operate but does not crank the engine.

Section N.7

REMOVING AND REPLACING THE STARTER

Release the starter cable from the terminal and unscrew the two starter securing bolts. Manoeuvre the starter forwards below the oil filter, then rearwards and upwards.

Section N.8

SERVICING THE STARTER

Examination of commutator and brush gear

Remove the starter cover band (A) (Fig. N.5) and examine the brushes (C) (Fig. N.5) and the commutator. Hold back each of the brush springs (B) (Fig. N.5) and move the brush by pulling gently on its

flexible connector. If the movement is sluggish remove the brush from its holder and ease the sides by lightly polishing with a smooth file. Always replace brushes in their original positions. If the brushes are worn so that they no longer bear on the commutator, or if the brush flexible lead has become exposed on the running face, they must be renewed.

If the commutator is blackened or dirty, clean it by holding a petrol-moistened cloth against it while the armature is rotated.

Secure the body of the starter in a vice and test by connecting it with heavy-gauge cables to a battery of the correct voltage. One cable must be connected to the starter terminal and the other held against the starter body or end bracket. Under these light load conditions the starter should run at a very high speed.

If the operation of the starter is still unsatisfactory, the starter should be dismantled for detailed inspection and testing.

Dismantling

Take off the cover band "A" (Fig. N.5) at the commutator end, hold back the brush springs "B" (Fig. N.5) and take out the brushes "C" (Fig. N.5) from their holders.

Withdraw the jump ring and shims from the armature

shaft at the commutator end and remove the armature complete with drive from the commutator end bracket and starter frame.

Remove the terminal nuts "E" and washers "F" from the terminal post "G" at the commutator end bracket and also withdraw the two through bolts. Remove the commutator end bracket and the attachment bracket from the starter frame.

Brushes

- Test the brush springs with a spring scale. The correct tension is 30-40 oz. (850-1134 gm.). Fit a new spring if the tension is low.
- If the brushes are worn so that they no longer bear on the commutator, or if the flexible connector has become exposed on the running face, they must be renewed. Two of the brushes are connected to terminals eyelets attached to the brush boxes on the commutator end bracket. The other two brushes (Fig. N.5) are connected to tappings on the field coils.

The flexible connectors must be removed by unsoldering and the connectors of the new brushes secured in place by soldering. The brushes are pre-formed, so that bedding of the working face to the commutator is unnecessary.

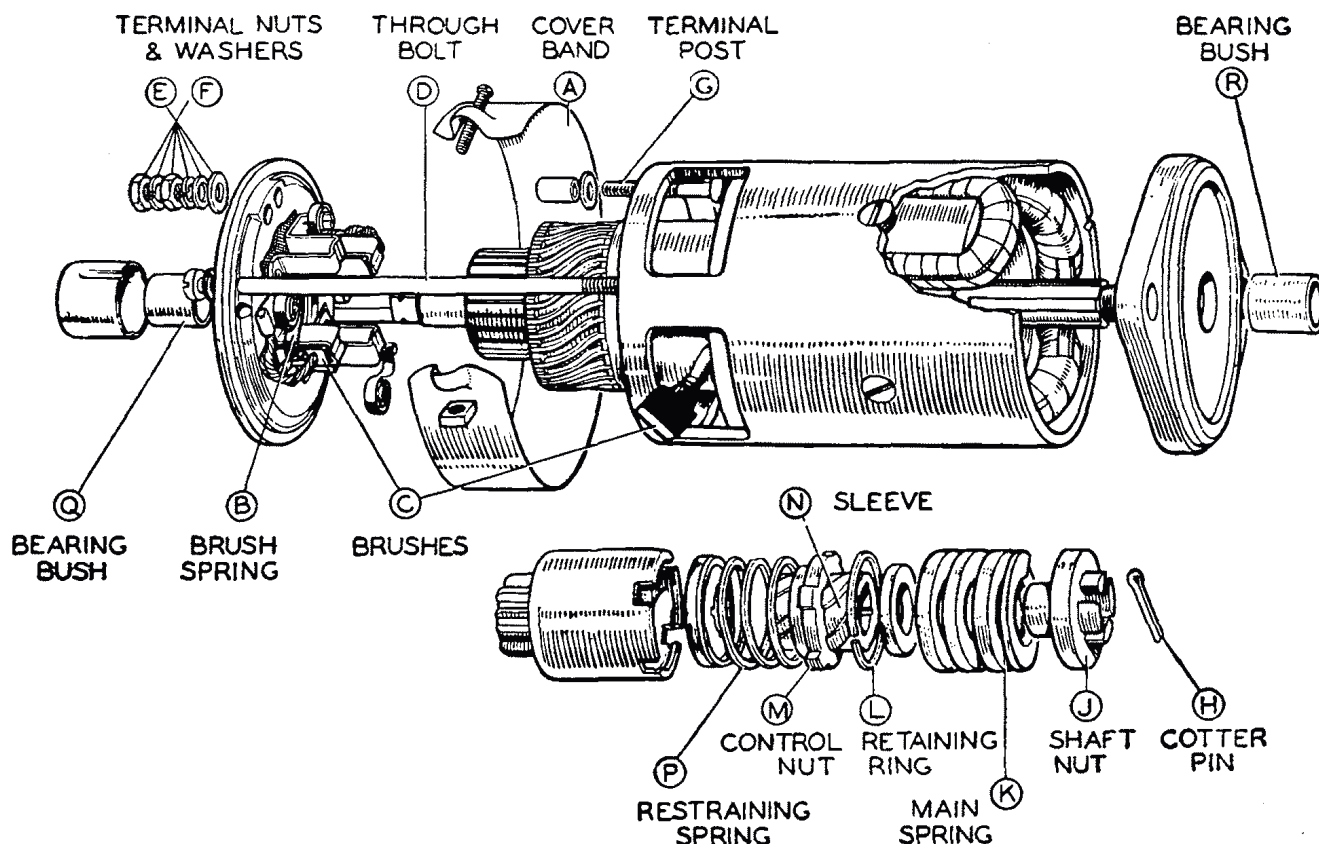

Fig. N.5.

An exploded view of the starter and drive.

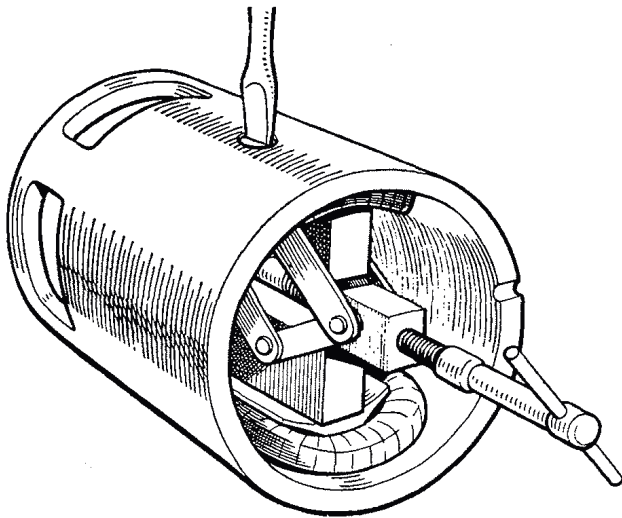

Fig. N.6.

An expander in use for fitting pole shoes.

Drive

If the pinion is tight on the sleeve, wash in paraffin; replace any worn or damaged parts.

To dismantle the drive, extract the split pin and remove the shaft nut "J" (Fig. N.5); withdraw the main spring and collar.

Rotate the barrel to push out the sleeve; remove the barrel and pinion.

The barrel and pinion are supplied as an assembly but the parts may be separated by extracting the retaining ring "L."

Note.—Should either the control nut or screwed sleeve be damaged, a replacement assembly, consisting of a screwed sleeve and control nut, must be fitted. These components must not be fitted individually.

Commutator

A commutator in good condition will be smooth and free from pits and burned spots. Clean the commutator with a cloth moistened with petrol. If this is ineffective, carefully polish with a strip of fine glass-paper, while rotating the armature. To remedy a badly worn commutator, dismantle the starter drive as described above and remove the armature from the end bracket. Now mount the armature in a lathe, rotate it at a high speed and take a light cut with a very sharp tool. Do not remove any more metal than is absolutely necessary, and finally polish with very fine glass-paper.

The mica on the starter commutator **must not be undercut.**

Field coils

The field coils can be tested for an open circuit by connecting a 12-volt battery, having a 12-volt bulb in

one of the leads, to the tapping point of the field coils to which the brushes are connected, and the field terminal post. If the lamp does not light, there is an open circuit in the wiring of the field coils.

Lighting of the lamp does not necessarily mean that the field coils are in order, as it is possible that one of them may be earthed to a pole shoe or to the yoke. This may be checked by removing the lead from the brush connector and holding it on a clean part of the starter yoke. Should the bulb now light it indicates that the field coils are earthed.

Should the above tests indicate that the fault lies in the field coils, they must be renewed. When renewing field coils carry out the procedure detailed in the Dynamo Section N.5.

Armature

Examination of the armature will in many cases reveal the cause of failure, e.g. conductors lifted from the commutator due to the starter being engaged while the engine is running and causing the armature to be rotated at an excessive speed. A damaged armature must in all cases be renewed—no attempt should be made to machine the armature core or to true a distorted armature shaft.

Bearings (commutator end)

Bearings which are worn to such an extent that they will allow excessive sideplay of the armature shaft must be renewed. To renew the bearing bush, proceed as follows:—

Press the new bearing bush into the end bracket, using a shouldered mandrel of the same diameter as the shaft which is to fit in the bearing.

The bearing bush is of the porous phosphor-bronze type, and before fitting, **new bushes should be allowed to stand completely immersed for twenty-four hours in thin engine oil in order to fill the pores of the bush with lubricant.**

Reassembly

The reassembly of the starter is a reversal of the operations described in this section.

Section N.9

THE CONTROL BOX

Regulator adjustment

The regulator is carefully set before leaving the Works to suit the normal requirements of the standard equipment, and in general it should not be necessary to alter it. If, however, the battery does not keep in a charged condition, or if the dynamo output does not fall when the battery is fully charged, it may be advisable to check the setting and, if necessary, to readjust it.

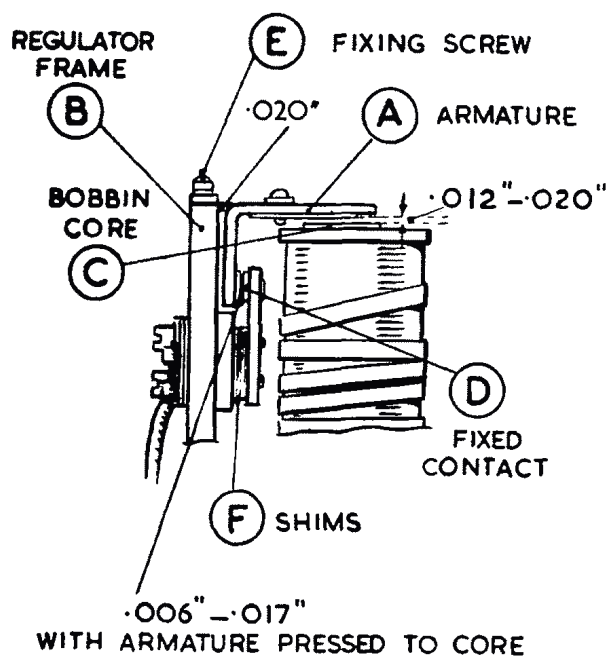

Fig. N.7

Mechanical regulator adjustment

It is important, before altering the regulator setting, when the battery is in a low state of charge, to check that its condition is not due to a battery defect or to the dynamo belt slipping.

How to check and adjust electrical setting

The regulator setting can be checked without removing the cover of the control box.

Withdraw the cables from the terminals marked 'A' and 'A1' at the control box and join them together. Connect the negative lead of a moving-coil voltmeter (0-20 volts full-scale reading) to the 'D' terminal on the dynamo and connect the other lead from the meter to a convenient chassis earth.

Slowly increase the speed of the engine until the voltmeter needle flicks and then steadies; this should occur at a voltmeter reading between the limits given below for the appropriate temperature of the regulator.

Setting at 10° C. (50° F.)	16.1-16.7 volts
„ „ 20° C. (68° F.)	15.8-16.4 „
„ „ 30° C. (86° F.)	15.6-16.2 „
„ „ 40° C. (104° F.)	15.3-15.9 „

If the voltage at which the reading becomes steady occurs outside these limits, the regulator must be adjusted.

Shut off the engine, remove the control box cover, release the locknut (A) (Fig. N.8) holding the adjusting screw (B) and turn the screw in a clockwise direction to raise the setting or in an anti-clockwise direction to lower the setting. Turn the adjusting screw a fraction of a turn and then tighten the locknut.

When the dynamo is run at a high speed on open circuit, it builds up a high voltage. When adjusting the regulator, do not run the engine up to more than 3,000 r.p.m. or a false voltmeter reading will be obtained.

Mechanical setting

The mechanical setting of the regulator is accurately adjusted before leaving the Works, and provided that the armature carrying the moving contact is not removed, the regulator will not require mechanical adjustment. If, however, the armature has been removed from the regulator for any reason, the contacts will have to be reset. To do this, proceed as follows:

- (1) Slacken the two armature fixing screws (E) (Fig. N.7). Insert a .020 in. (.51 mm.) feeler gauge between the back of the armature (A) and the regulator frame.
- (2) Press back the armature against the regulator frame and down onto the top of the bobbin core with the gauge in position and lock the armature by tightening the two fixing screws.
- (3) Check the gap between the under side of the arm and the top of the bobbin core. This must be .012 to .020 in. (.30 to .51 mm.). If the gap is outside these limits correct by adding or removing shims (F) (Fig. N.7) at the back of the fixed contact (D) or, in later types, by carefully bending the fixed contact bracket.
- (4) Remove the gauge and press the armature down, when the gap between the contacts should be between .006 in. (.15 mm.) and .017 in. (.43 mm.).

Cleaning contacts

To render the regulator contacts accessible for cleaning, slacken the screws securing the plate carrying the fixed contact. It will be necessary to slacken the upper screw (C) (Fig. N.8) a little more than the lower screw (D), so that the contact plate can be swung outwards. Clean the contacts by means of fine carborundum stone or fine emery-cloth. Carefully wipe away all traces of dirt or other foreign matter. Finally tighten the securing screws.

CUT-OUT**Adjustment**

If it is suspected that the cutting-in speed of the dynamo is too high, connect a voltmeter between the terminals marked 'D' and 'E' at the control box and slowly raise the engine speed. When the voltmeter reading rises to between 12.7 and 13.3 volts the cut-out contacts should close.

If the cut-out has become out of adjustment and operates at a voltage outside these limits it must be reset. To make the adjustment, slacken the locknut (E) (Fig. N.8) and turn the adjusting screw (F) a fraction of a turn in a clockwise direction to raise the operating voltage

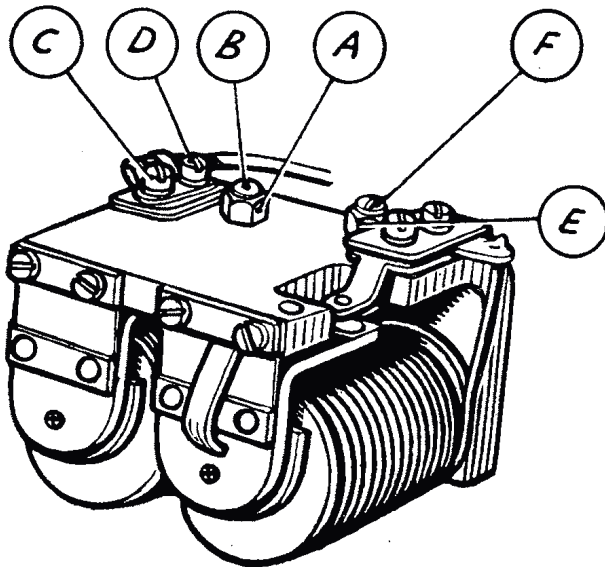

Fig. N.8

The cut-out and regulator assembly

or in an anti-clockwise direction to lower the voltage. Tighten the locknut after making the adjustment.

Cleaning

To clean the contacts remove the cover, place a strip of fine glass-paper between the contacts and then, closing the contacts by hand, draw the paper through. This should be done two or three times, with the rough side towards each contact.

Radio suppression

When it is desired to fit suppressors for radio equipment, make sure that this is done only in accordance with recommended practice. Suppressors and capacitors wrongly fitted may cause damage to the electrical equipment.

Section N.10

FUSES

The fuses are mounted in a separate fusebox and are therefore accessible without removing the control box cover.

Units protected

The units which are protected by each fuse can readily be identified by referring to the wiring diagram on page N.14.

Blown fuses

A blown fuse is indicated by the failure of all the units protected by it, and is confirmed by examination of the fuse, which can easily be withdrawn from the spring clips.

If it has blown, the fused state of the wire will be visible inside the glass tube. Before renewing a blown fuse, inspect the wiring of the units that have failed for evidence of a short circuit or other faults which may have caused the fuse to blow, and remedy the cause of the trouble.

Section N.11

THE ELECTRIC HORN

If the horn fails or becomes uncertain in its action, it does not follow that the horn has broken down. First ascertain that the trouble is not due to a loose or broken connection in the wiring of the horn. If the fuse has blown, examine the wiring for the fault and replace with the spare fuse provided.

The performance of a horn may be upset by a loose fixing bolt, or by some component near the horn being loose. If after carrying out the above examination the trouble is not rectified, the horn may need adjustment.

Adjustment does not alter the pitch of the note: it merely takes up wear of moving parts. When adjusting the horn, short-circuit the fuse, otherwise it is liable to blow. Again, if the horn will not sound on adjustment, release the push instantly.

Adjustment

Remove the fixing screw from the top of the horn and take off the cover. Detach the cover securing bracket by springing it out of its location.

Slacken the locknut on the fixed contact and rotate the adjusting nut until the contacts are just separated (indicated by the horn failing to sound). Turn the adjusting nut half a turn in the opposite direction and secure it in this position by tightening the locknut.

Section N.12

FLASHING DIRECTION INDICATORS

The flashing direction indicators are operated by a pneumatic time switch through a flasher unit and a relay to the dual-filament bulbs in the side and tail lamps. In the event of failure, carry out the following procedure:

- (1) Check bulbs for broken filaments.
- (2) Refer to the wiring diagram and check over flasher circuit connections.
- (3) Switch on the ignition and check that terminal 'B' on the flasher is at 12 volts with respect to earth.
- (4) Connect together terminals 'B' and 'L' at the flasher unit and operate the direction indicator switch.

If the flasher lights now work, the flasher unit is defective and must be renewed.

If the lights do not work the relay is defective and must be renewed.

The length of time the flasher is operating can be altered by screwing up the adjusting screw located in the small boss at the back of the time switch. Screw in to lengthen the time of operation and out to shorten the period.

Section N.13

THE WINDSHIELD WIPER

Normally the windshield wiper will not require any servicing apart from the occasional renewal of the rubber blades.

Should any trouble be experienced, first check for loose connections, worn insulation, etc., before dismantling the motor.

1. To detach the cable rack from the motor and gearbox

Unscrew the pipe union nut.

Remove the gearbox cover.

Remove the split pin and washer from the crank-pin and final gear wheel.

Lift off the connecting link.

2. Commutator dirty

Remove the connecting leads to the terminals, and withdraw the three screws securing the cover at the commutator end. Lift off the cover. Clean the commutator with a cloth moistened with petrol (gasoline) and carefully remove any carbon dust from between the commutator segments.

3. Brush lever stiff or brushes not bearing on commutator

Check that the brushes bear freely on the commutator. If they are loose and do not make contact, a replacement

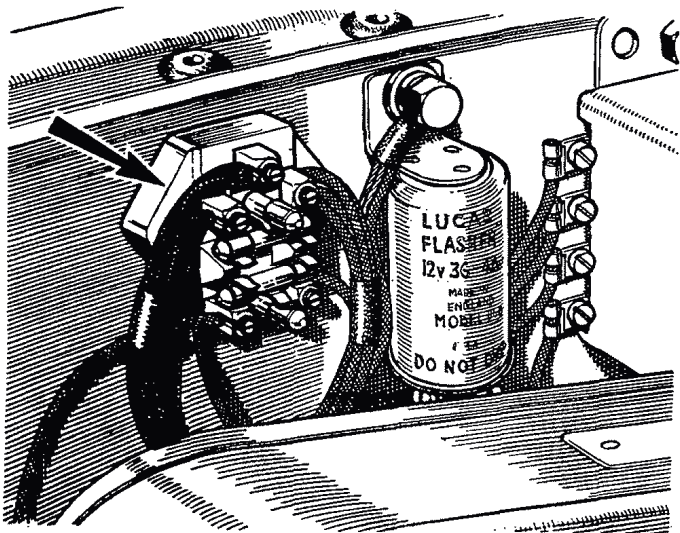

Fig. N.9

The fuses and flasher unit

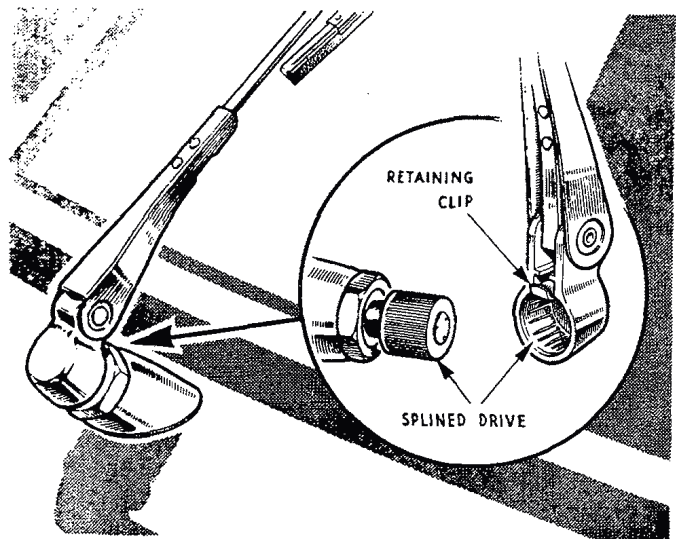

Fig. N.10

A windshield wiper arm and drive

tension spring is necessary. The brush levers must be free on their pivots. If they are stiff they should be freed by working them backwards and forwards by hand and by applying a trace of thin machine oil. Packing shims are fitted beneath the legs of the brush to ensure that the brushes are central and that there is no possibility of the brush boxes fouling the commutator. If the brushes are considerably worn they must be replaced by new ones.

4. Motor operates but does not transmit motion to spindles

Remove the cover of the gearbox. A push-pull motion should be transmitted to the inner cable of the flexible rack. If the cross-head moves sluggishly between the guides, lightly smear a small amount of medium grade engine oil in the groove formed in the die-cast housing. When overhauling, the gear must be lubricated by lightly packing the gearbox with a grease to Ref. D (page P.2).

5. Thrust screw adjustments

The thrust screw is located on the top of the cross-head housing. To adjust, slacken the locknut, screw down the thrust screw until it contacts the armature and then turn back a fraction of a turn. Hold the thrust screw with a screwdriver and tighten the locknut.

6. To remove the motor

Detach the cable rack from the motor and gearbox as detailed above. Disconnect the lead. Remove the two screws securing the mounting bracket to remove the motor.

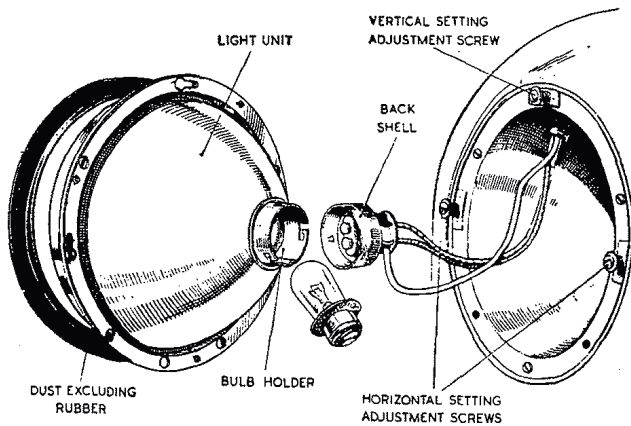

Fig. N.11
A light unit

Section N.14

THE HEADLAMPS

The headlamps are built into the wings and are fitted with double-filament bulbs. The design is such that the bulb is correctly positioned in relation to the reflector, and no focusing is required when a replacement bulb is fitted.

The anti-dazzle device

The double-filament bulbs are controlled by a foot-operated dipping switch deflecting both headlamp beams downwards to avoid dazzle.

Certain countries have lighting regulations to which the foregoing arrangements do not conform, and cars exported to such countries have suitably modified lighting equipment.

Section N.15

THE LIGHT UNITS

The light units consist of a lamp glass, reflector, and a back shell. The light unit is located to the front wing by three spring-loaded attachment screws in a domed shield attached to the wing. The back of the lamp is therefore sealed to give complete protection.

A dust- and weather-excluding rubber is fitted in the recess of the rim of the light unit and a plated rim is fitted over this to complete the weather-sealing.

Section N.16

REMOVING THE LIGHT UNITS

To remove the light unit for bulb replacement, unscrew the retaining screw at the bottom of the plated lamp rim and lift the rim away from the dust-excluding rubber.

Remove the dust-excluding rubber, which will reveal the three spring-loaded screws. Press the light unit inwards against the tension of the springs and turn it in an anti-clockwise direction until the heads of the screws can pass through the enlarged ends of the keyhole slots in the lamp rim.

This will enable you to withdraw the light unit sufficiently to give attention to the wiring and bulbs.

Section N.17

SETTING THE HEADLAMPS

The lamps should be set so that the main driving beams are parallel with the road surface or in accordance with your local regulations.

If adjustment is required, this is achieved by removing the plated rim and dust-excluding rubber as indicated in Section N.16.

Vertical adjustment can then be made by turning the screws at the top of the lamp in the necessary direction.

Horizontal adjustment can be effected by using the adjustment screws on each side of the light unit. (See Fig. N.12.)

Section N.18

REPLACING HEADLAMP BULBS

Twist the back shell anti-clockwise and pull it off. Withdraw the bulb from the holder.

Insert the replacement bulb in the holder, making sure that the slot in the periphery of the bulb flange engages the projection in the holder.

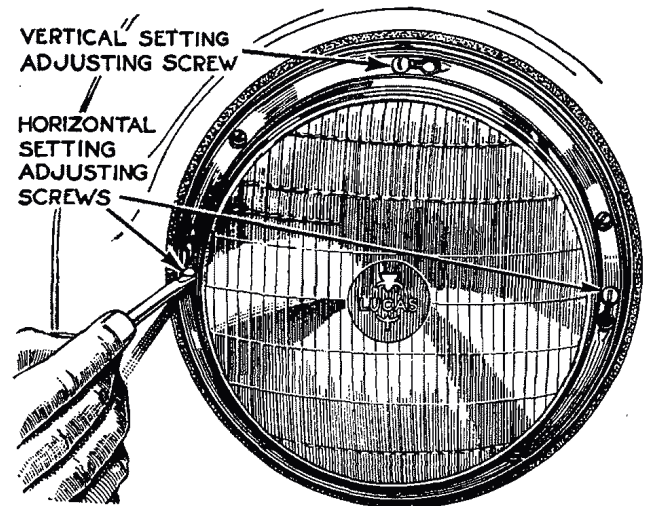

Fig. N.12
The headlamp setting screws

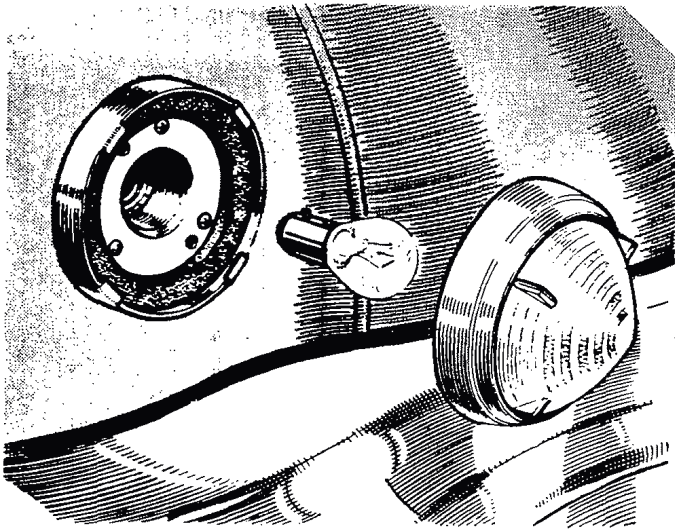

Fig. N.13.
Sidelamp bulb removal.

Engage the projections on the back shell with the slots of the holder, press it on and twist it clockwise until it engages with its catch.

Section N.19

REPLACING THE LIGHT UNITS

Position the light unit so that the heads of the adjusting screws coincide with the enlarged ends of the attachment slots. Push the light unit towards the wing to compress the springs and turn the unit to the right as far as it will go, that is, approximately $\frac{1}{2}$ in. (13 mm.).

Replace the dust-excluding rubber on the light rim with its flanged face forward and refit the plated rim.

Section N.20

THE TAIL-LAMPS AND STOP-LIGHTS

The tail-lamps are of the double-filament type, the second filament giving a marked increase in brilliance when the brakes are applied.

To obtain access to the bulbs, remove the glass by withdrawing the two screws. The bulbs are held in bayonet-type holders with offset pins to ensure correct fitting.

Section N.21

CLEANING THE LAMPS

Care must be taken when handling headlamp reflectors to prevent them from becoming finger-marked. If they do become marked a transparent and colourless protective covering enables any finger-marks to be removed

by polishing with a chamois-leather or a very soft dry cloth. **Do not use metal polish on reflectors.**

Chromium-plated surfaces such as lamp rims should be washed with plenty of water, and when the dirt is completely removed they may be polished with a chamois-leather or soft dry cloth. **Do not use metal polishes on chromium plating.**

Section N.22

THE SIDELAMPS

To obtain access to the bulb press the lamp front inwards and turn it anti-clockwise until it is free to be withdrawn. Reverse this movement to replace the front.

The locating pins on the bulbs are offset to ensure that it is fitted correctly to give increased brilliance when the flashing equipment is operating.

Section N.23

THE NUMBER-PLATE ILLUMINATION

The number-plate is illuminated by a separate lamp and the domed cover is removed for bulb replacement by unscrewing the slotted screw and withdrawing the cover.

Section N.24

THE PANEL AND WARNING LIGHTS

The locations of the lamps illuminating the instruments and the warning lights are shown by arrows on the illustrations on page N.15.

The bulbs are accessible from below the instrument panel.

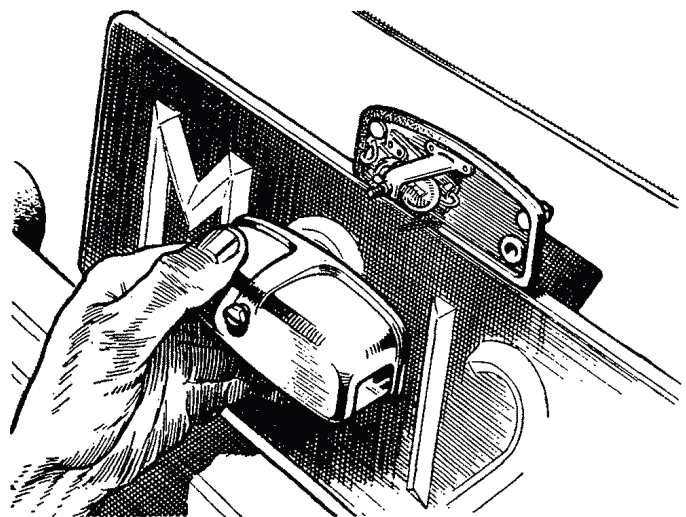
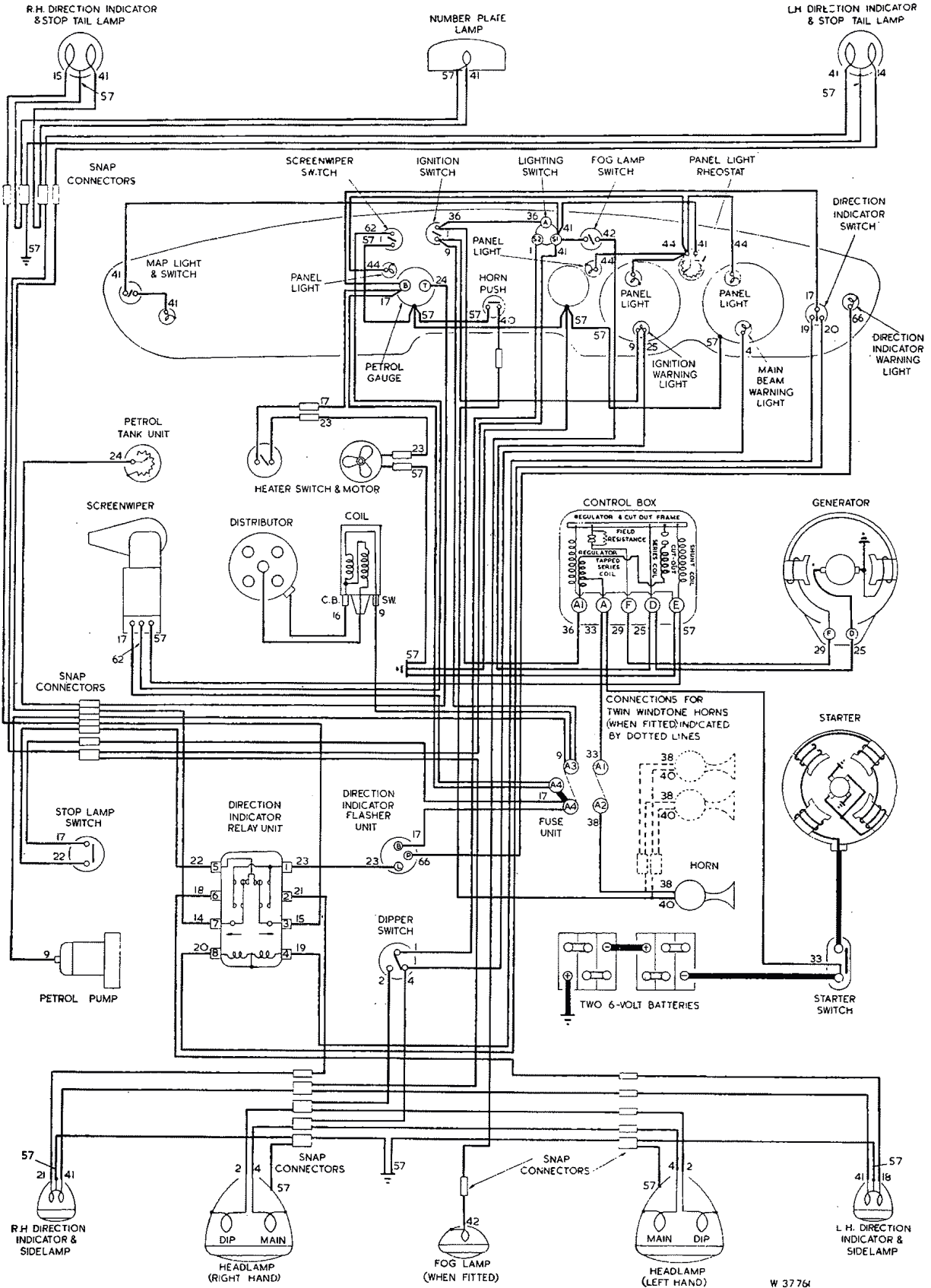

Fig. N.14.
The number-plate lamp.

WIRING DIAGRAM



W 3776

For index to cable colour code numbers see page N.15.

Section N.25

REPLACEMENT BULBS

	B.M.C. Part No.	Watts	Volts
Headlamps (Home and Export R.H.D.—dip left)	13H140	50/40	12
Headlamps (Europe and U.S.A. L.H.D.—dip right)	13H141	50/40	12
Headlamps (Europe except France—vertical dip)	3H921	45/40	12
Headlamps (Europe except France—vertical dip) from Car No. 58918	13H138	45/40	12
Headlamps (France—vertical dip) from Car No. 60340	13H139	45/40	12
Sidelamp and stop/tail lamp	1F9026	6/21	12
Number-plate illumination lamp	2H4817	6	12
Panel lamps	2H4732	2.2	12

Section N.26

FITTING A FOG LAMP

A fog lamp is not fitted as standard equipment, but can be supplied as an optional extra. The necessary wiring together with the switch (marked 'F' on the instrument panel) is already provided to accommodate the fitment.

To fit a fog lamp bracket remove the over-rider and place the bracket in position. Mark off and drill a further hole through the bumper to accommodate an additional $\frac{1}{8}$ in. screw.

When mounted the lamp is connected up to the spare red and yellow lead located behind the radiator grille to the right-hand side.

The necessary parts are shown below, together with their part reference numbers.

ADH785	Fog lamp	2
AHH5454	Lead—fog lamp	2
AHH5521	Bracket—right-hand	1
AHH5520	Bracket—left-hand	1
RG103	Grommet—lead..	4
HZS0506	Screw—bracket to blade—lower	2
FNZ105	Nut	2
LWZ205	Spring washer	2
PMP0518	Screw	2
PMP105	Washer	2

Section N.27

LOCATION AND REMEDY OF FAULTS

Although every precaution is taken to eliminate possible causes of trouble, failure may occasionally develop through lack of attention to the equipment, or

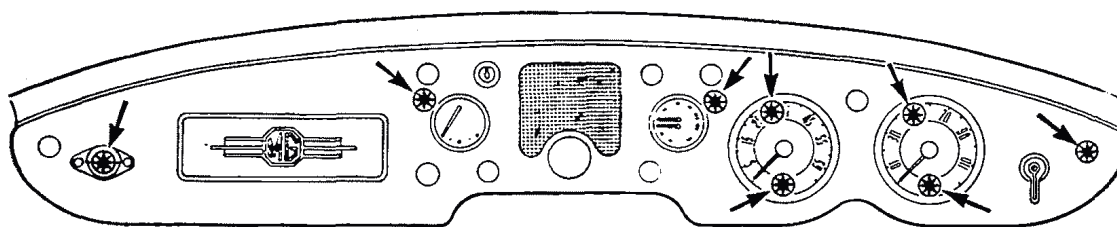

Fig. N.15

The panel and warning lights

KEY TO CABLE COLOURS

1 Blue	15 White with Brown	28 Yellow with White	41 Red	54 Purple with Green
2 Blue with Red	16 White with Black	29 Yellow with Green	42 Red with Yellow	55 Purple with Brown
3 Blue with Yellow	17 Green	30 Yellow with Purple	43 Red with Blue	56 Purple with Black
4 Blue with White	18 Green with Red	31 Yellow with Brown	44 Red with White	57 Black
5 Blue with Green	19 Green with Yellow	32 Yellow with Black	45 Red with Green	58 Black with Red
6 Blue with Purple	20 Green with Blue	33 Brown	46 Red with Purple	59 Black with Yellow
7 Blue with Brown	21 Green with White	34 Brown with Red	47 Red with Brown	60 Black with Blue
8 Blue with Black	22 Green with Purple	35 Brown with Yellow	48 Red with Black	61 Black with White
9 White	23 Green with Brown	36 Brown with Blue	49 Purple	62 Black with Green
10 White with Red	24 Green with Black	37 Brown with White	50 Purple with Red	63 Black with Purple
11 White with Yellow	25 Yellow	38 Brown with Green	51 Purple with Yellow	64 Black with Brown
12 White with Blue	26 Yellow with Red	39 Brown with Purple	52 Purple with Blue	65 Dark Green
13 White with Green	27 Yellow with Blue	40 Brown with Black	53 Purple with White	66 Light Green

damage to the wiring. The following pages set out the recommended procedure for a systematic examination to locate and remedy the causes of some of the more usual faults encountered.

The sources of trouble are by no means always obvious, and in some cases a considerable amount of deduction from the symptoms is needed before the cause is disclosed.

For instance, the engine might not respond to the starter switch; a hasty inference would be that the starter motor is at fault. However, as the motor is dependent on the batteries, it may be that the batteries are exhausted.

This, in turn, may be due to the dynamo failing to charge the batteries, and the final cause of the trouble may be, perhaps, a loose connection in some part of the charging circuit.

If, after carrying out an examination, the cause of the trouble is not found, the equipment should be checked by the nearest Lucas Service Depot or Agent.

CHARGING CIRCUIT

1. Batteries in low state of charge

- (a) This state will be shown by lack of power when starting, poor light from the lamps, and hydrometer readings below 1.200. It may be due to the dynamo not charging or giving low or intermittent output. The ignition warning light will not go out if the dynamo fails to charge, or will flicker on and off in the event of intermittent output.
- (b) Examine the charging and field circuit wiring, tightening any loose connections or replacing broken cables. Pay particular attention to the battery connections.
- (c) Examine the dynamo driving belt; take up any undue slackness by swinging the dynamo outwards on its mounting after slackening the attachment bolts.
- (d) Check the regulator setting and adjust if necessary.
- (e) If, after carrying out the above, the trouble is still not cured, have the equipment examined by a Lucas Service Depot or Agent.

2. Batteries overcharged

This will be indicated by burnt-out bulbs, very frequent need for topping up the batteries, and high hydrometer readings. Check the charge reading with an ammeter when the car is running. It should be of the order of only 3-4 amperes.

If the ammeter reading is in excess of this value, it is advisable to check the regulator setting and adjust if necessary.

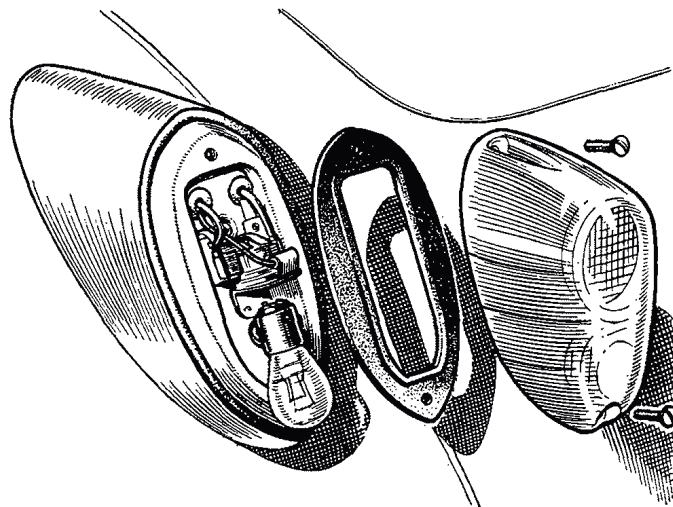

Fig. N.16
Removing a tail lamp bulb

STARTER MOTOR

1. Starter motor lacks power or fails to turn engine

- (a) See if the engine can be turned over by hand. If not, the cause of the stiffness in the engine must be located and remedied.
- (b) If the engine can be turned by hand, first check that the trouble is not due to a discharged battery.
- (c) Examine the connections to the batteries, starter and starter switch, making sure that they are tight and that the cables connecting these units are not damaged.
- (d) It is also possible that the starter pinion may have jammed in mesh with the flywheel, although this is by no means a common occurrence. To disengage the pinion, rotate the squared end of the starter shaft by means of a spanner.

2. Starter operates but does not crank engine

This fault will occur if the pinion of the starter drive is not allowed to move along the screwed sleeve into engagement with the flywheel, due to dirt having collected on the screwed sleeve. Remove the starter and clean the sleeve carefully with paraffin (kerosene).

3. Starter pinion will not disengage from flywheel when engine is running

Stop the engine and see if the starter pinion is jammed in mesh with the flywheel, releasing it if necessary by rotation of the squared end of the starter shaft. If the pinion persists in sticking in mesh, have the equipment examined at a Service Depot. Serious damage may result to the starter if it is driven by the flywheel.

LIGHTING CIRCUITS

1. Lamps give insufficient illumination

- (a) Test the state of charge of the battery, recharging it if necessary from an independent electrical supply.
- (b) Check the setting of the lamps.
- (c) If the bulbs are discoloured as the result of long service, they should be renewed.

2. Lamps light when switched on but gradually fade out As paragraph 1 (a).

3. Brilliance varies with speed of car

- (a) As paragraph 1 (a).
- (b) Examine the battery connections, making sure that they are tight, and renew any faulty cables.

Section N.28

WINDOWLESS YOKE DYNAMO

Engines numbered from 487 are fitted with a new dynamo (Part No. 11G220) without brush gear inspection windows (see Fig. N.17). Access to the brush gear in these dynamos is gained by undoing the two through-bolts and withdrawing the commutator end bracket. Every 12,000 miles (19200 km.) the unit should be partially dismantled for the inspection of brush gear and commutator.

To check the brush spring tension, the yoke should

be completely withdrawn from the armature and the commutator end bracket refitted to the shaft.

When reassembling a windowless yoke dynamo the brushes must first be held clear of the commutator in the usual way, i.e. by partially withdrawing the brushes from their boxes until each brush is trapped in position by the side pressure of its spring. The brushes can be released onto the commutator with a small screwdriver or similar tool when the end bracket is assembled to within about $\frac{1}{2}$ in. (13 mm.) of the yoke. Before closing the gap between the end bracket and yoke, see that the springs are in correct contact with the brushes.

Coil steady plate, Part No. 11G221, should always be used with dynamo, Part No. 11G220.

Section N.29

MODIFIED CONTROL BOX

A modified C.V.C. control box, model RB106/2, with revised settings (Part No. AHH5356) is introduced on later cars. Servicing instructions remain as before (see Section N.9), but adjustments must be made within 30 seconds, otherwise heating of the shunt winding will cause false settings to be made.

The voltmeter readings should be within the limits given below at approximately 1,500 dynamo r.p.m. and according to the ambient temperature:

- Setting at 10° C. (50° F.) .. 15.9 to 16.5 volts
- Setting at 20° C. (68° F.) .. 15.6 to 16.2 volts
- Setting at 30° C. (86° F.) .. 15.4 to 16.0 volts
- Setting at 40° C. (104° F.) .. 15.1 to 15.7 volts

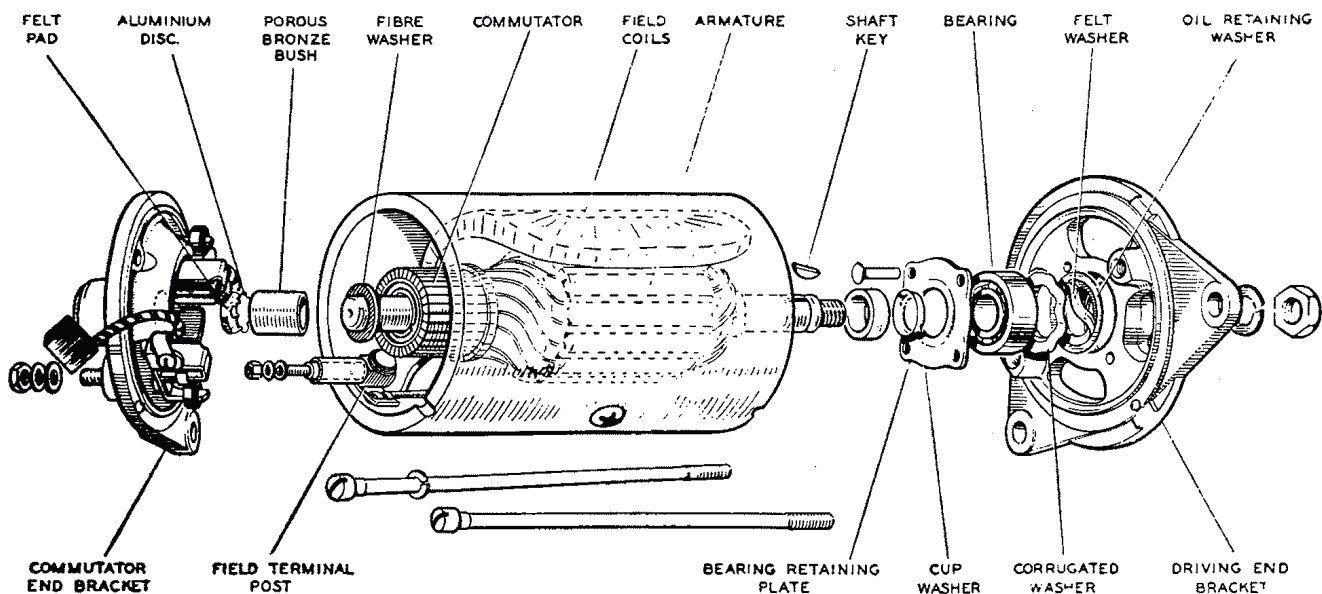

Fig. N.17

The windowless yoke dynamo

Section N.30

HEADLAMP BEAM SETTING

Refer to Section N.17 for details of the headlamp adjustment screws.

In the absence of specialized proprietary equipment the setting of the lamps can be carried out by placing the vehicle squarely in front of a blank wall at a distance of 25 ft. (7.6 m.) or more, taking care that the surface on which the car is standing is level and not sloping in relation to the wall. The vehicle should be loaded. It will be found an advantage to cover one lamp while setting the other.

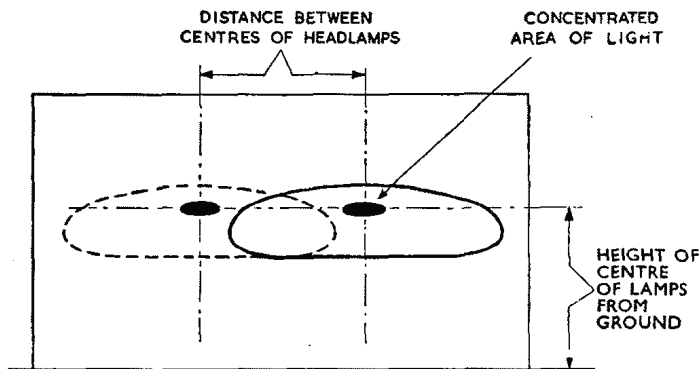

Fig. N.18

Headlamp—alignment

Section N.31

DRY-CHARGED BATTERIES

'Dry-charged' batteries are supplied without electrolyte but with the plates in a charged condition. This ensures that there is no deterioration of the battery if it is stored for a period before use. These batteries have the type suffix letter 'Z' (e.g. SGZ, etc.).

Filling the cells with electrolyte of the correct specific gravity (see 'Initial filling and charging' of Section N.1) **in one operation** renders the battery capable of giving a starting discharge **one hour after filling**. The temperature of the filling-in solution, battery, and filling room should be maintained between 60° F. (16° C.) and 100° F. (38° C.). If the battery has been stored in a cool place, it should be allowed to warm up to room temperature before filling.

When time permits, a freshening charge at the normal recharge rate of the battery will ensure that the battery is fully charged. During the charge keep the electrolyte level with the top edge of the separators by the addition of distilled water. Check the electrolyte specific gravity

at the end of the charge: if 1.270 acid was used to fill the battery, the specific gravity should now be between 1.270 and 1.290; if 1.210 acid was used, the specific gravity should be between 1.210 and 1.230.

Section N.32

MODIFIED EUROPEAN LIGHT UNIT

Cars exported to Europe are now fitted with the new European-type headlamps. These lamp units are fitted with special bulbs and front lenses giving an asymmetrical beam to the right-hand side. This modification was introduced on the following cars:

From Car No. 58918 (Europe except France).

From Car No. 60340 (France).

Access to the bulb is gained in the same way as described in Section N.16. The bulb, however, is released from the reflector by withdrawing the three-pin socket and pinching the two ends of the wire retaining clip to clear the bulb flange (see Fig. N.18).

When replacing the bulb care must be taken to see that the rectangular pip on the bulb flange engages the slot in the reflector seating for the bulb.

Replace the spring clip with its coils resting in the base of the bulb flange and engaging in the two retaining lugs on the reflector seating.

The appropriate replacement bulbs are listed in Section N.25. They are not interchangeable with those used in conjunction with the Continental-type headlamps previously fitted.

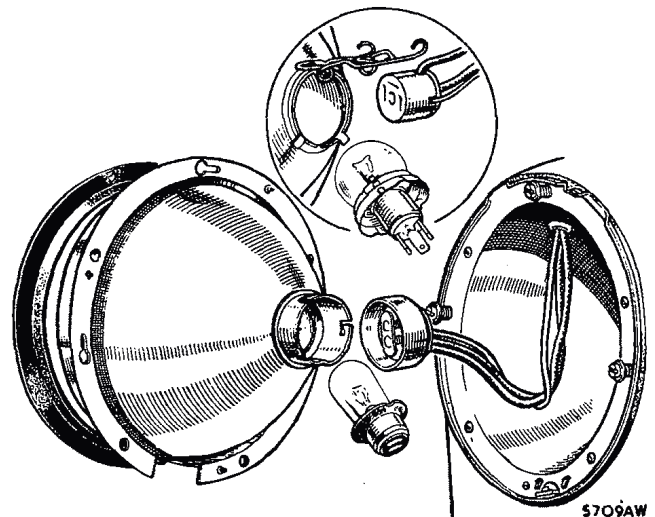

Fig. N.19

The headlamp light unit, with the European-type lamp bulb arrangement inset

SECTION NN

THE ELECTRICAL EQUIPMENT

(MGA 1600 and MGA 1600 [Mk. II])

- | | |
|-------------------|--------------------------------------------------|
| Section No. NN.1 | Front pilot and flashing indicator lamps. |
| Section No. NN.2 | Rear flashing indicator lamps. |
| Section No. NN.3 | Replacement bulbs. |
| Section No. NN.4 | Headlamps. |
| Section No. NN.5 | Lucas C40/1 dynamo. |
| Section No. NN.6 | Dismantling a C40/1 dynamo. |
| Section No. NN.7 | Servicing a C40/1 dynamo. |
| Section No. NN.8 | Control box RB106/2 (modified). |
| Section No. NN.9 | Mk. X sealed-beam headlamps. |
| Section No. NN.10 | Tail/stop and flasher lamps (MGA 1600 [Mk. II]). |

WIRING DIAGRAM (MGA 1600)

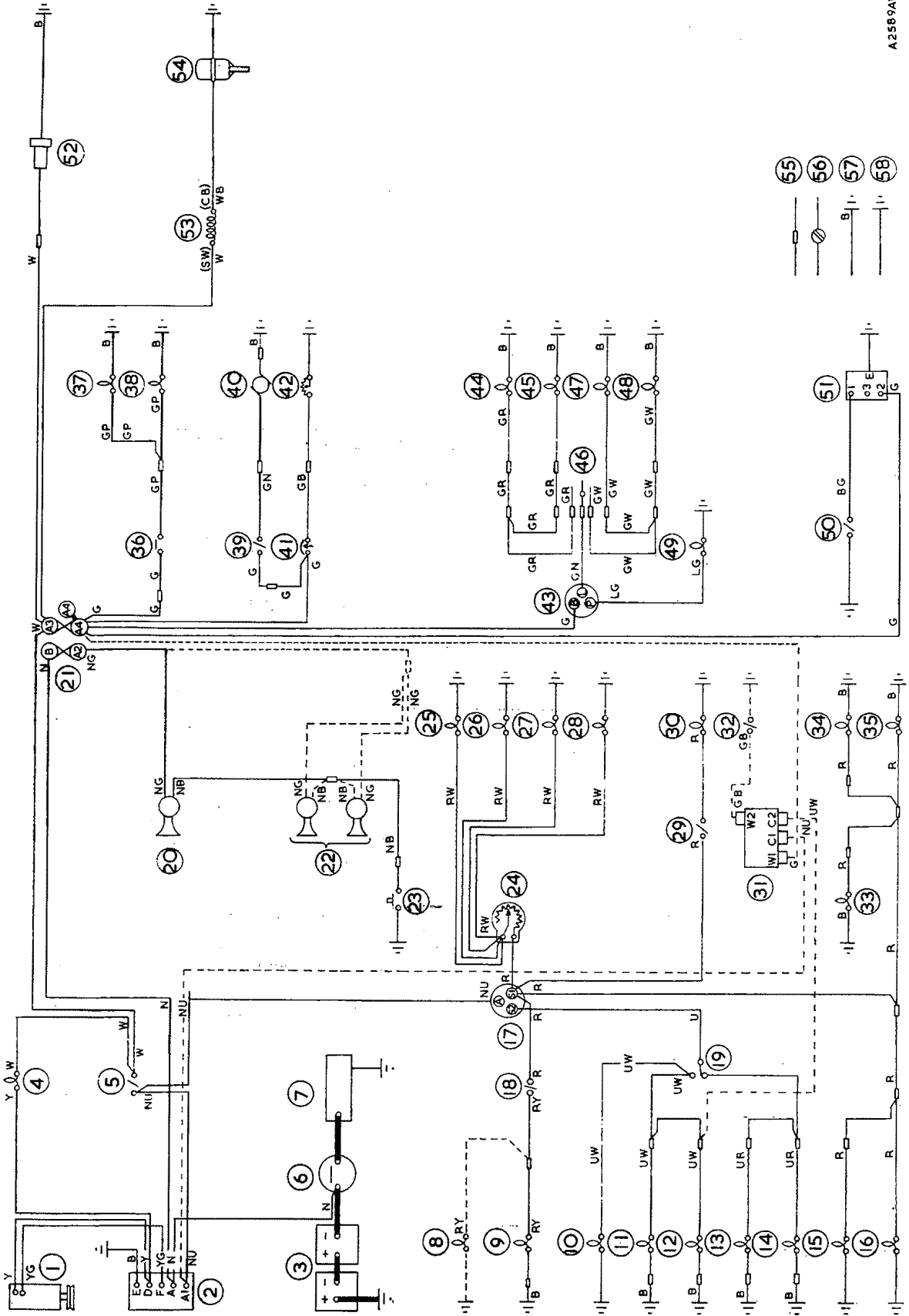

A2589AW

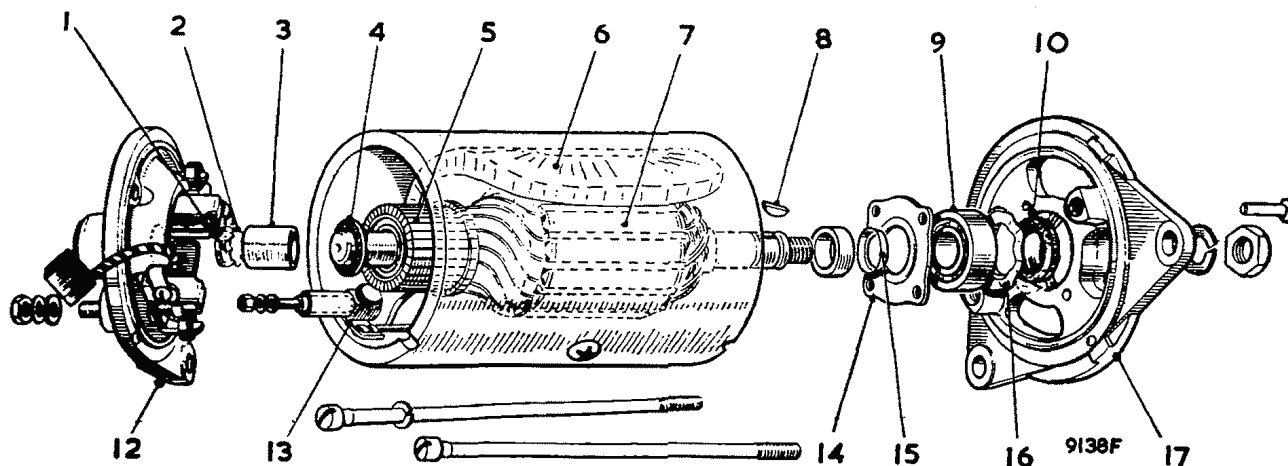

Fig. NN.2

The C40/1 dynamo

- | | | |
|--------------------|-----------------------------|------------------------------|
| 1. Felt pad. | 7. Armature. | 13. Field terminal post. |
| 2. Aluminium disc. | 8. Shaft key. | 14. Bearing retaining plate. |
| 3. Bronze bush. | 9. Bearing. | 15. Cup washer. |
| 4. Fibre washer. | 10. Felt washer. | 16. Corrugated washer. |
| 5. Commutator. | 12. Commutator end bracket. | 17. Driving end bracket. |
| 6. Field coils. | | |

Section NN.7

SERVICING A C40/1 DYNAMO

The instructions for servicing the dynamos are generally the same as given in Section N.5, with the following exceptions.

Brushes

The minimum permissible length of a worn brush is $\frac{3}{8}$ in. (7.14 mm.). Badly worn brushes must be renewed and the new brushes bedded to the commutator. The correct spring tension is 30 oz. (.85 kg.), maximum, on a new brush, and 13 oz. (.37 kg.), minimum, on a brush worn to $\frac{3}{8}$ in. (7.14 mm.).

Commutator

The later type of commutators are moulded, and may be reskinned to a minimum diameter of 1.450 in. (36.8 mm.). The undercut must conform to the following dimensions:

- Width .. .040 in. (1.016 mm.)
 Depth .. .020 to .035 in. (.508 to .889 mm.)

It is important that the side of the undercut should clear the moulding material by a minimum of .015 in. (.381 mm.).

Field coil

The resistance of the field coil is 6.0 ohms.

Bearings

To remove the bearing bush in the commutator end

plate screw a $\frac{3}{8}$ in. tap squarely into the bush and withdraw the bush: then remove the felt ring and its retainer.

When refitting the bearing plate to the front bracket insert the rivets from the outer face of the bracket.

The part numbers of the new components are as follows:

Dynamo, Lucas type C40/1	13H219
Ignition coil bracket	12H51
Control box, Lucas, Type RB106/2 ..	3H1836

Section NN.8

MODIFIED RB106/2 CONTROL BOX

The instructions for adjusting the modified Lucas Type RB106/2 control box are as follows.

Regulator adjustment

The electrical setting of the control unit can be checked without removing the cover. Use a good-quality moving-coil voltmeter (0 to 20 volts).

Remove the cables from the control box terminals 'A' and 'A1' and connect the cables together.

Connect the negative lead of the voltmeter to the control box terminal 'D' and connect the other lead to the terminal 'E'.

Run the dynamo at 3,000 r.p.m., and watch the voltmeter reading, which should be between the limits given below, according to the ambient temperatures.

KEY TO WIRING DIAGRAM (R.H.D. AND L.H.D.)

No.	Description	No.	Description	No.	Description
1.	Generator.	21.	Fuse unit.	40.	Heater motor.
2.	Control box.	22.	Twin windtone horns (if fitted).	41.	Fuel gauge.
3.	Two 6-volt batteries.	23.	Horn-push.	42.	Fuel tank unit.
4.	Ignition warning light.	24.	Panel lamp rheostat.	43.	Flasher unit.
5.	Ignition switch.	25.	Panel lamp.	44.	L.H. rear flasher.
6.	Starter switch.	26.	Panel lamp.	45.	L.H. front flasher.
7.	Starter motor.	27.	Panel lamp.	46.	Flasher switch.
8.	R.H. fog lamp (if fitted).	28.	Panel lamp.	47.	R.H. front flasher.
9.	L.H. fog lamp.	29.	Map lamp switch.	48.	R.H. rear flasher.
10.	Main beam warning light.	30.	Map lamp.	49.	Flasher warning light.
11.	R.H. headlamp main beam.	31.	Headlamp flick relay.	50.	Windshield wiper switch.
12.	L.H. headlamp main beam.	32.	Headlamp flick switch.	51.	Windshield wiper motor.
13.	L.H. headlamp dip beam.	33.	L.H. tail lamp.	52.	Fuel pump.
14.	R.H. headlamp dip beam.	34.	Number-plate lamp.	53.	Ignition coil.
15.	L.H. pilot lamp.	35.	R.H. tail lamp.	54.	Distributor.
16.	R.H. pilot lamp.	36.	Stop lamp switch.	55.	Snap connectors.
17.	Lighting switch.	37.	L.H. stop lamp.	56.	Terminal blocks or junction box.
18.	Fog lamp switch.	38.	R.H. stop lamp.	57.	Earth connections made via cable.
19.	Dipper switch.	39.	Heater switch (when fitted).	58.	Earth connections made via fixing bolts.
20.	Horn.				

CABLE COLOUR CODE

B	Black	P	Purple	Y	Yellow
U	Blue	R	Red	D	Dark
N	Brown	S	Slate	L	Light
G	Green	W	White	M	Medium
K	Pink				

When a cable has two colour code letters the first denotes the main colour and the second denotes the tracer colour

Section NN.1

FRONT PILOT AND FLASHING INDICATOR LAMPS

To gain access to the front pilot and flashing indicator bulbs press the front of the lamp inwards and turn it in a clockwise direction.

Both bulbs have single filaments and may be replaced either way round.

Section NN.2

REAR FLASHING INDICATOR LAMPS

Fold back the rubber lip surrounding the lamp rim and withdraw the rim and lens.

The bulb has a single filament and may be replaced either way round.

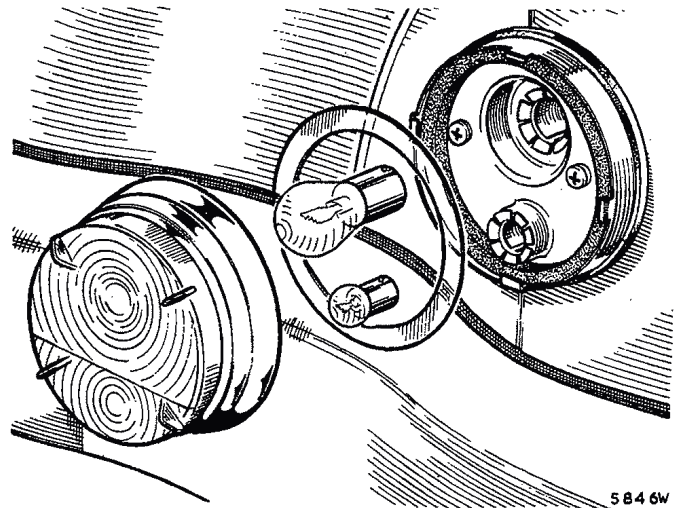

Fig. NN.1

A front pilot and flashing indicator bulb with the lens and rim removed

Section NN.3

REPLACEMENT BULBS

	B.M.C. Part No.	Watts	Volts
Headlamps (Home and Export R.H.D.—dip left)	13H140	50/40	12
Headlamps (Export and U.S.A. L.H.D.—dip right)	13H141	50/40	12
Headlamps (Europe except France—dip vertical)	13H138	45/40	12
Headlamps (France L.H.D.—dip vertical)	13H139	45/40	12
Headlamps (Sweden R.H.D.—dip vertical)	3H921	45/40	12
Headlamps (Sweden R.H.D.—left dip, from Car No. 72040) ..	13H138	45/40	12
Stop/tail lamps	1F9026	6/21	12
Number-plate illumination lamp	2H4817	6	12
Flashing indicator lamps	1F9012	21	12
Panel lamps	2H4732	2-2	12

Section NN.4

HEADLAMPS

From Car No. 70222 Mk. VIII headlamps with sealed-beam units (Part No. BHA4144) were fitted to cars exported to U.S.A.

From Car No. 72040 cars exported to Sweden have special headlamps with asymmetrical left dip (Part No. BMK391). These are interchangeable with earlier types in pairs only.

Section NN.5

LUCAS C40/1 DYNAMO

From Engine No. 16GA6272 a later type of dynamo with increased output, Lucas type C40/1, was introduced,

complete with Lucar connectors, modified Lucas type RB106/2 control box, and a new-type ignition coil bracket.

The modified control box must not be fitted with the earlier-type dynamo.

Section NN.6

DISMANTLING A C40/1 DYNAMO

The instructions for dismantling the dynamo are basically the same as those given in Section N.4. The C40/1 dynamo has a windowless yoke, and is therefore not fitted with a cover band.

Access to the brushes is obtained by removing the commutator end bracket.

Ambient temperature	Open-circuit voltage
50° F. (10° C.)	16.1 to 16.7
68° F. (20° C.)	16.0 to 16.6
86° F. (30° C.)	15.9 to 16.5
104° F. (40° C.)	15.8 to 16.4

An unsteady voltmeter reading may be due to dirty contacts, but if the reading is outside the appropriate limits the regulator must be adjusted.

Switch off the engine, remove the control box cover, restart the engine, and run the dynamo at 3,000 r.p.m. Turn the regulator adjusting screw (1, Fig. NN.3) in a clockwise direction to raise the setting, or in an anti-clockwise direction to lower the setting.

NOTE.—The operations of checking and adjusting the regulator should be completed within 30 seconds, otherwise false readings and settings, due to the heating of the shunt coil, will be made.

After adjustment a further check of the setting should be made by switching off and restarting the engine and then raising the dynamo speed to 3,000 r.p.m., when the open-circuit voltage must conform to the figures stated.

Refit the control box cover and restore the original connections.

Cut-out adjustments

To check the voltage at which the cut-out operates remove the control box cover and connect the voltmeter between terminals 'D' and 'E'.

Start the engine and slowly increase speed until the cut-out contacts are seen to close, noting the voltage at which this occurs. It should be 12.7 to 13.3 volts.

An alternative method of determining the exact point of contact closure is to switch on an electrical load, such as a pair of headlamps, when the instant of contact closure will be indicated by a slight flick of the voltmeter pointer.

If the cut-out operates outside the above limits it will be necessary to adjust it to within the limits. To do this turn the adjusting screw (2, Fig. NN.3) in a clockwise direction to raise the setting or in an anti-clockwise direction to reduce the setting.

Turn the screw only a fraction of a turn at a time and test the setting after each adjustment by increasing the engine speed from zero and noting the voltmeter reading at the instant of contact closure.

NOTE.—Like the regulator, the setting of the cut-out must be carried out as quickly as possible to avoid errors due to the heating of the shunt coil.

Having set the cut-in voltage correctly, the 'drop-off' setting should now be checked, and adjusted if necessary so that the instant of contact opening occurs between 8.5 and 11.0 volts.

To check the voltage at which the contacts open remove the control box cover, disconnect the cables from the control box terminals 'A' and 'A1', and join these cables together. Connect the voltmeter between terminal 'A1' and earth; start the engine and run up to speed.

Decelerate the engine slowly and watch the voltmeter pointer, which will return to zero immediately the contact points open. The opening of the contacts should occur between 8.5 and 11.0 volts.

Should the opening of the contacts occur outside these limits, the setting of the fixed contact must be adjusted.

Using a pair of thin-nosed pliers, carefully bend the fixed contact blade towards the bobbin to reduce the drop-off voltage, or away from the bobbin to increase the drop-off voltage. After each adjustment, which should be very small, test the setting, as previously described, and readjust as necessary.

Restore the original connections and refit the cover.

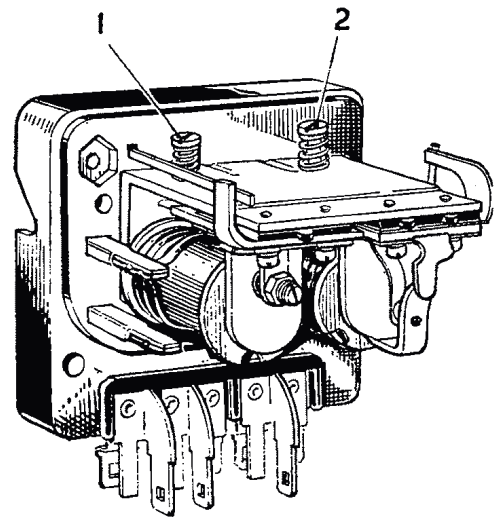

AI A F D E A1273.

Fig. NN.3

The control box with cover removed

1. Regulator adjusting screw.
2. Cut-out adjusting screw.

Section NN.9

Mk. X SEALED-BEAM HEADLAMPS

Commencing at Chassis No. 103857, Mk. X sealed-beam light units are fitted to all cars exported to the U.S.A.

The lamp housing is secured to the wing by four screws and the back-shell is retained in the housing by a single coil spring. Two screws, each having a flange beneath its head, engage in slotted lugs on the rim of the back-shell and bear against the lamp housing; the screws are used

to adjust the vertical and horizontal alignment. The lamp wiring passes through the housing and terminates in a three-hole socket.

Three pins at the back of the sealed-beam unit engage the holes in the socket, and the unit is retained in the back-shell by a lamp retaining plate that is secured to the back-shell by three screws. The lamp rim engages two lugs at the top of the housing and is retained in position by a screw.

To gain access to the lamp unit remove the rim retaining screw and lift the rim off the locating lugs. Slacken the three lamp retaining plate screws, turn the plate anti-clockwise, and remove it from the back-shell. Withdraw the lamp unit and disengage the three-pin plug.

To refit the lamp unit engage the three-pin plug and place the unit in the back-shell; ensure that the three lugs formed on the rear circumference of the unit engage the slots in the back-shell. Refit the lamp retaining plate, press it firmly, and rotate it in a clockwise direction to the full extent of the slotted holes. Tighten the retaining plate screws. Fit the rim over the locating lugs, press the rim downwards and inwards, and secure it with its retaining screw.

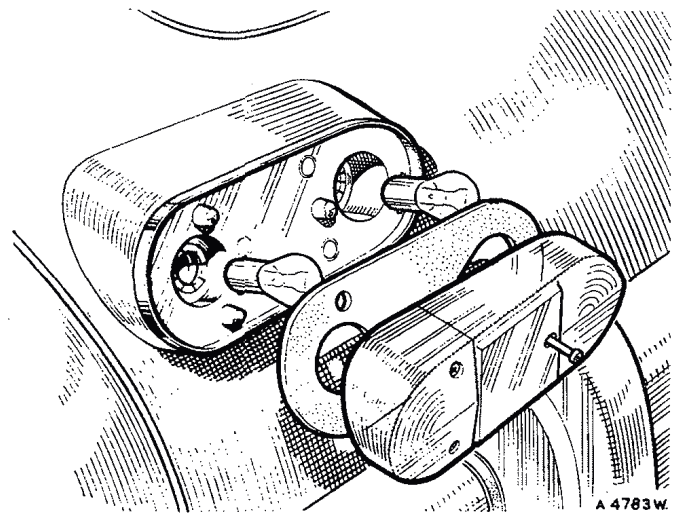

Fig. NN.2

To gain access to the flasher lamp bulb only remove the two outer screws and slide off the flasher lamp cover. To gain access to the tail/stop lamp bulb remove all three screws and the two-piece cover complete

Section NN.10

TAIL/STOP AND FLASHER LAMPS (MGA 1600 [Mk. II])

Each tail/stop flasher lamp is secured to the tail plinth by two screws. The plinths incorporate two studs that pass through the body shell and are secured by washers and nuts.

The tail/stop and flasher lamp is a combined unit and is enclosed in a two-piece cover that incorporates a sealed reflector. The tail/stop lamp cover is secured by a single screw; the flasher cover slides onto one end of the tail/stop lamp cover and is secured by two screws.

A 24-watt single-filament bulb is used in the flasher lamp and a 21/6-watt double-filament bulb is used in the tail/stop lamp bulb. To ensure that the stop light gives the brighter light the tail/stop lamp bulb has offset pegs and can only be fitted in one position.

To gain access to the flasher lamp bulb only, remove the two outer screws and slide off the flasher lamp cover. To gain access to the tail/stop lamp bulb remove all three screws and the two-piece cover complete.

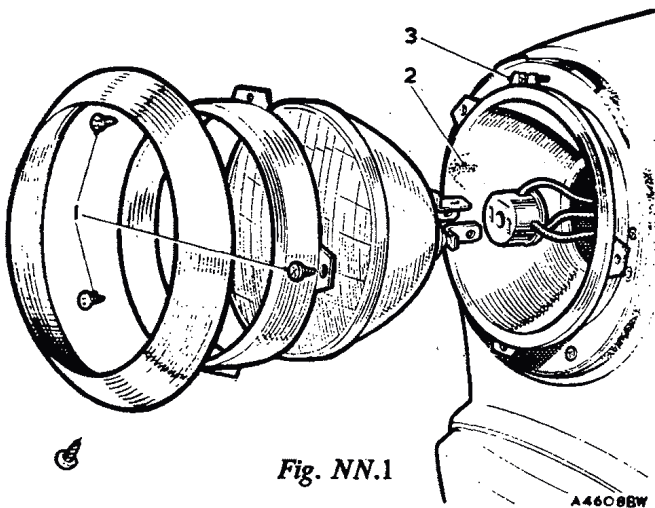

Fig. NN.1

The sealed-beam headlamp, showing the locating lugs and:

1. Retaining plate screw.
2. Horizontal adjustment screw.
3. Vertical adjustment screw.

