

# LUBRICATION CHART

## KEY TO LUBRICATION CHART

### DAILY

- (1) ENGINE. Check the oil level with the dipstick. Replenish if necessary with new oil (Ref. A).

### EVERY 1,000 MILES (1600 Km.)

- (2) STEERING. Give three or four strokes with the lubricating gun filled to Ref. C to the nipples on the steering joints on both sides of the car.
- (3) GEARBOX. Check the oil level with the dipstick. Replenish if necessary with new oil (Ref. A).
- (4) REAR AXLE. Replenish the oil to the level of the filler plug hole. Use new oil (Ref. B).
- (5) HAND BRAKE. Give the cable nipple three or four strokes with the gun filled with grease (Ref. C).
- (6) PROPELLER SHAFT. Give the nipples three or four strokes with the gun filled to Ref. C.
- (7) CARBURETTORS. Remove the cap from each suction chamber and insert a small quantity of oil (Ref. D).

### EVERY 3,000 MILES (4800 Km.)

- (8) ENGINE. Drain the used oil from the sump. Refill to the 'MAX' mark on the dipstick with new oil (Ref. A).

### EVERY 6,000 MILES (9600 Km.)

- (9) DISTRIBUTOR. Withdraw the rotating arm and add a few drops of oil (Ref. D) to the spindle and also to the advance mechanism. Smear the cam and contact pivot with grease or oil.
- (10) GEARBOX. Drain the used oil and refill to the 'HIGH' mark on the dipstick with new oil (Ref. A).
- (11) REAR AXLE. Drain the used oil and refill to the level of the filler plug hole with new oil (Ref. B).
- (12) FRONT HUBS. Remove the front wheel hub nuts and grease caps. Fill the caps with grease (Ref. C) and replace.
- (13) OIL FILTER. Renew the element and wash the bowl in fuel.
- (14) WATER PUMP. Give the nipple one stroke only with the gun filled with S.A.E. 140 oil.

### EVERY 12,000 MILES (19200 Km.)

- (15) STEERING RACK. Give up to 10 strokes to the nipple on the steering rack and two strokes only to the pinion shaft nipple with the gun filled with oil (Ref. B).
- (16) DYNAMO. Add two drops of oil (Ref. D) to the oil hole in the rear end bearing plate.

**NOTE.**—Oil and grease references are to be found on page P.7.

# LUBRICATION CHART

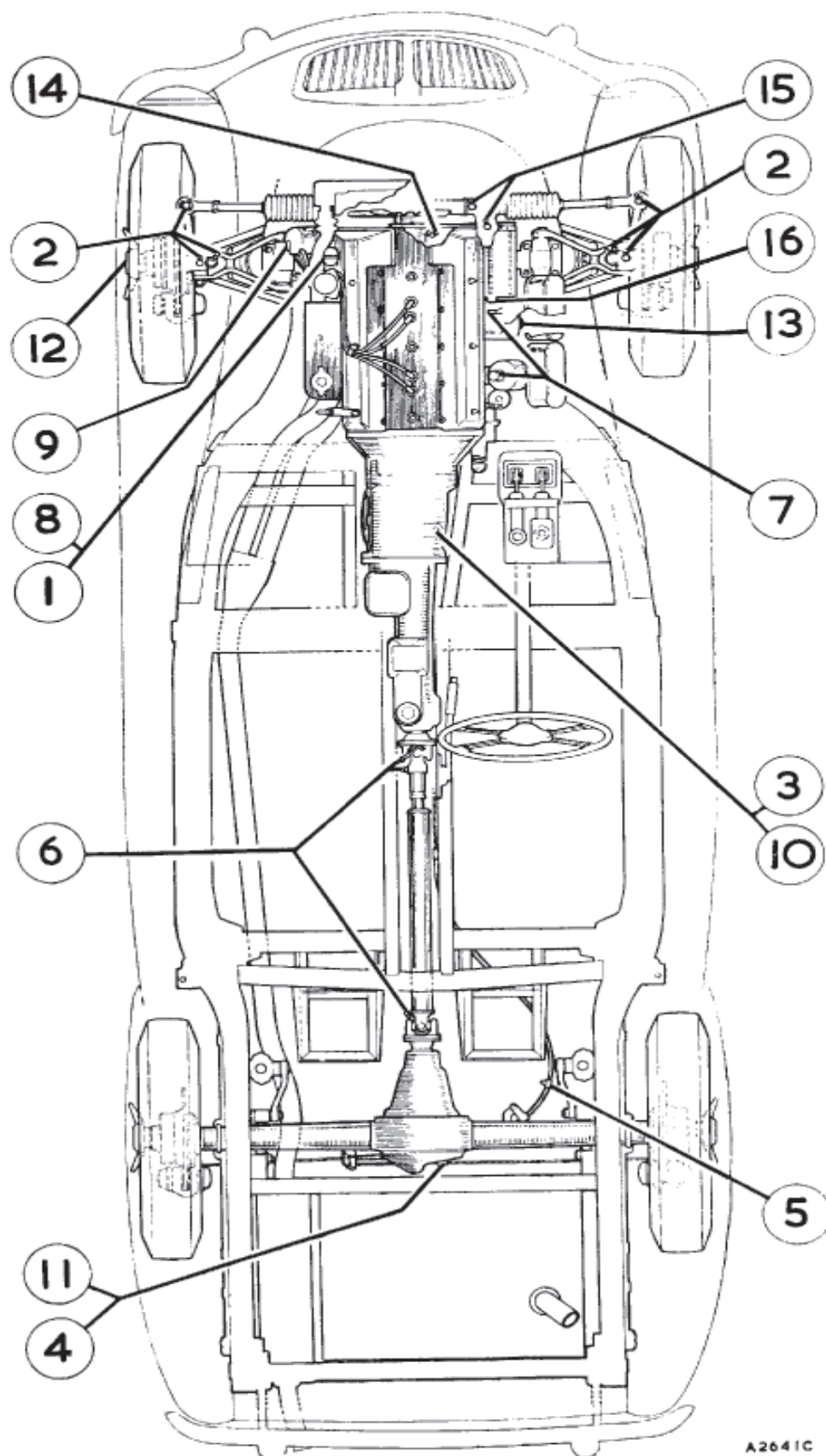

A2641C

PRINTED IN ENGLAND BY  
THE NUFFIELD PRESS LIMITED  
COWLEY, OXFORD  
29/22 (28152) 12/69—253