

Carb-Sync is fully adjustable to service Side-Draft or Down-Draft carburetors.

Carb-Sync

Multiple Carburetor Synchronizer

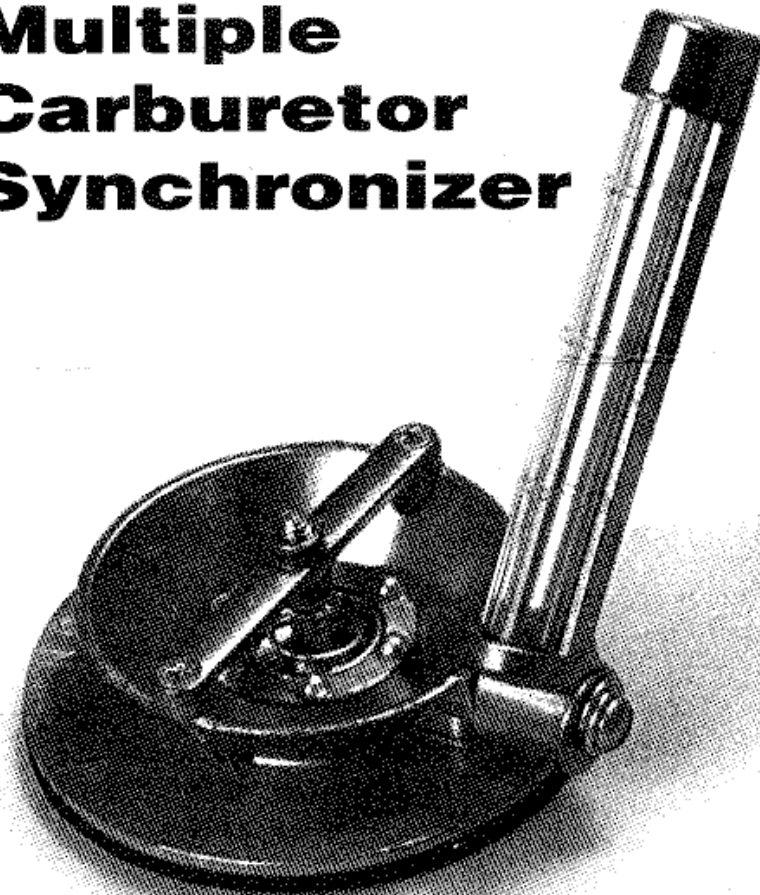

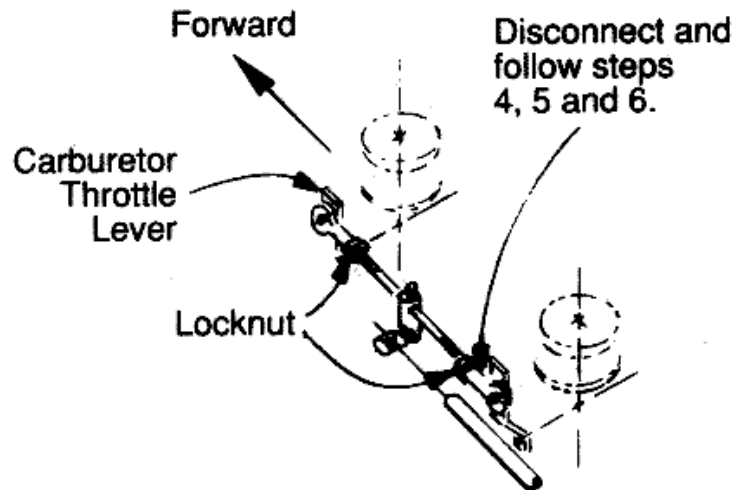

Illustration A
Carburetor throttle lever
pointed toward
road side (or curb side).

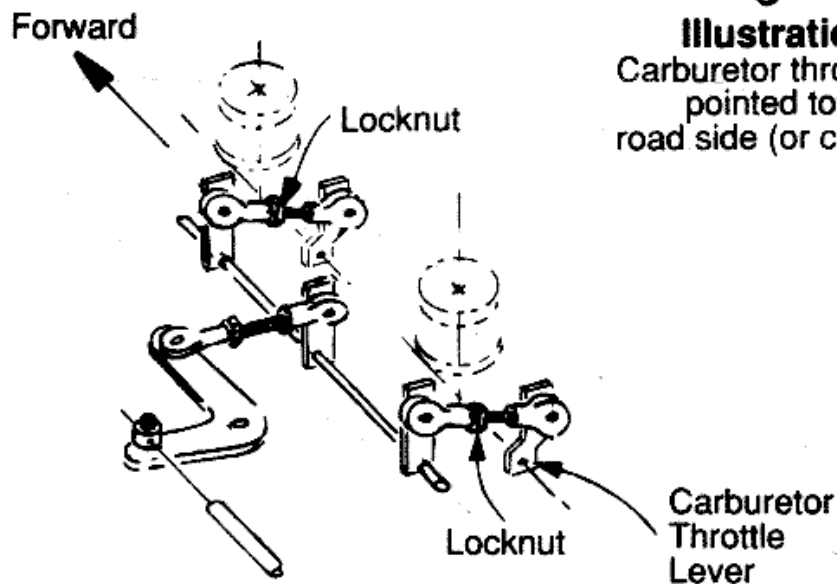

Illustration B
Carburetor throttle lever
pointed toward rear
(or front).

OPERATING INSTRUCTIONS

For smooth idle and best operation of any car with multiple carburetors, synchronization—carburetors working concurrently—is a must. By carefully following steps 1 through 8, maximum results can be achieved in a minimum amount of time. Refer to illustration A or B for basic linkage types for adjustment in steps 4, 5 & 6, or refer to vehicle manual for linkage adjustment.

- Step 1:** Warm engine to normal operating temperature.
- Step 2:** Remove air cleaner(s).
- Step 3:** Adjust idle screws to factory specifications.
- Step 4:** With engine at idle, disconnect throttle to all carburetors except one. Place Carb-Sync on carburetor still connected, with air flow control (A) in an open position. Gradually turn downward until float (B) in tube rises to centerline of tube (C).
- Step 5:** With links still disconnected – and **WITHOUT CHANGING AIR CONTROL (A) OF CARB-SYNC**—place carb-sync on each remaining carburetor. Set each carburetor throttle stop screw to bring the float to the same level as the first carburetor setting.
- Step 6:** Adjust remaining links so that when they are connected to throttle levers, float (B) remains the same and all levers move at the same time.
- Step 7:** If idle speed is too fast, back off each idle screw the same amount until proper idle is attained. Re-check with Carb-Sync, making certain float is in the same position for each carburetor. If not, repeat steps 4, 5 and 6.