

**CONFIDENTIAL**

MG / 305

# SERVICE MEMORANDUM

MGF/43

9 March 1960

SLUSH PENETRATION -  
FRONT & REAR BRAKE DRUMS

MGA

The possibility of slush penetrating into the brake drums may be eliminated by fitting splash guards of 20 S.W.G. mild steel.

These should be made to the dimensions given in the sketch and spot-welded to the rear face of the brake backplates at intervals of  $1\frac{1}{2}$ " (38.1 mm.), as indicated.

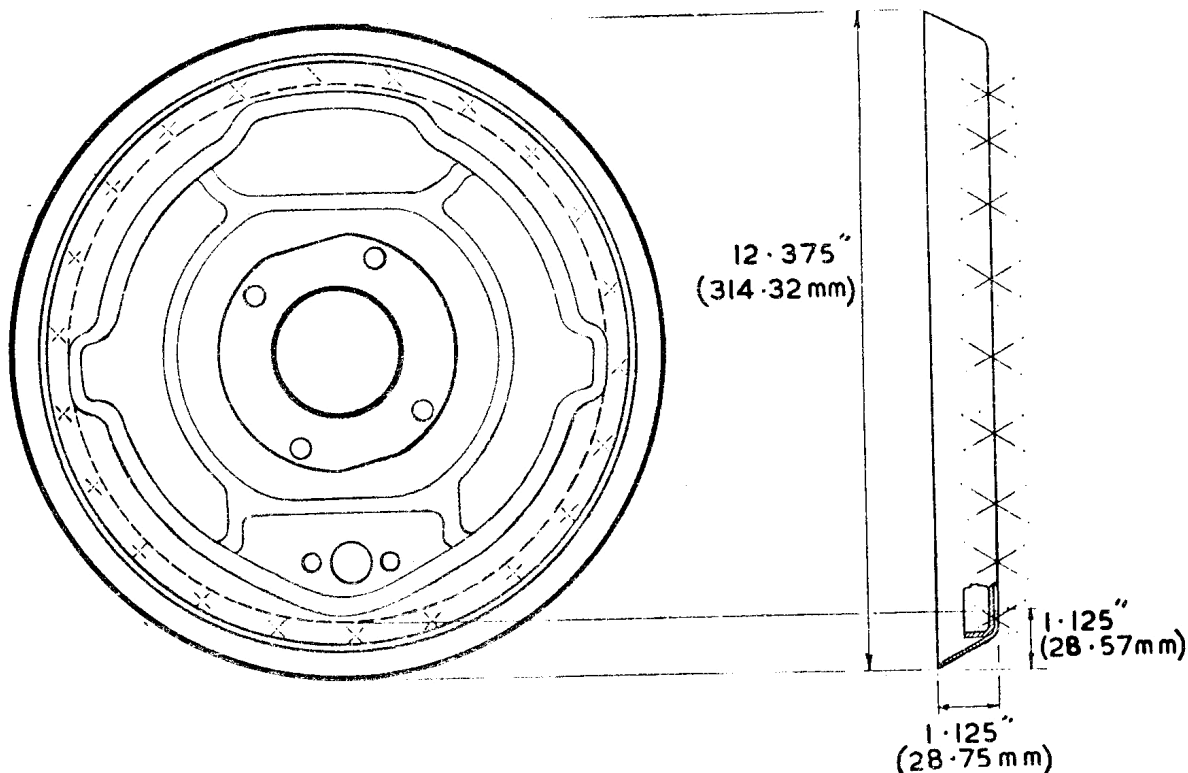

N.B. The splash guards will NOT be available from B.M.C. Service Ltd. and must be locally manufactured.