

WIPER MOTOR SUPPORT BRACKET FOR MGA
 TO BE FORMED AS SHOWN ON NEXT PAGE

INSTALL THREADED STUDS, THIN HEAD,
 (1) 1/4-28-UNF X 5/8, AND
 (2) #10-32-UNF X 1/2 AS SHOWN.
 SELF-CLINCHING PEM STUDS PREFERRED.
 MAY ALSO USE PROJECTION WELDED STUDS.

IF IT DOESN'T HAVE TO BE CONCURS ORIGINAL,
 MAY USE STANDARD FULL THREAD MACHINE SCREW WITH
 ANY FLAT SURFACE HEAD STYLE, AND TACK WELD IN PLACE.

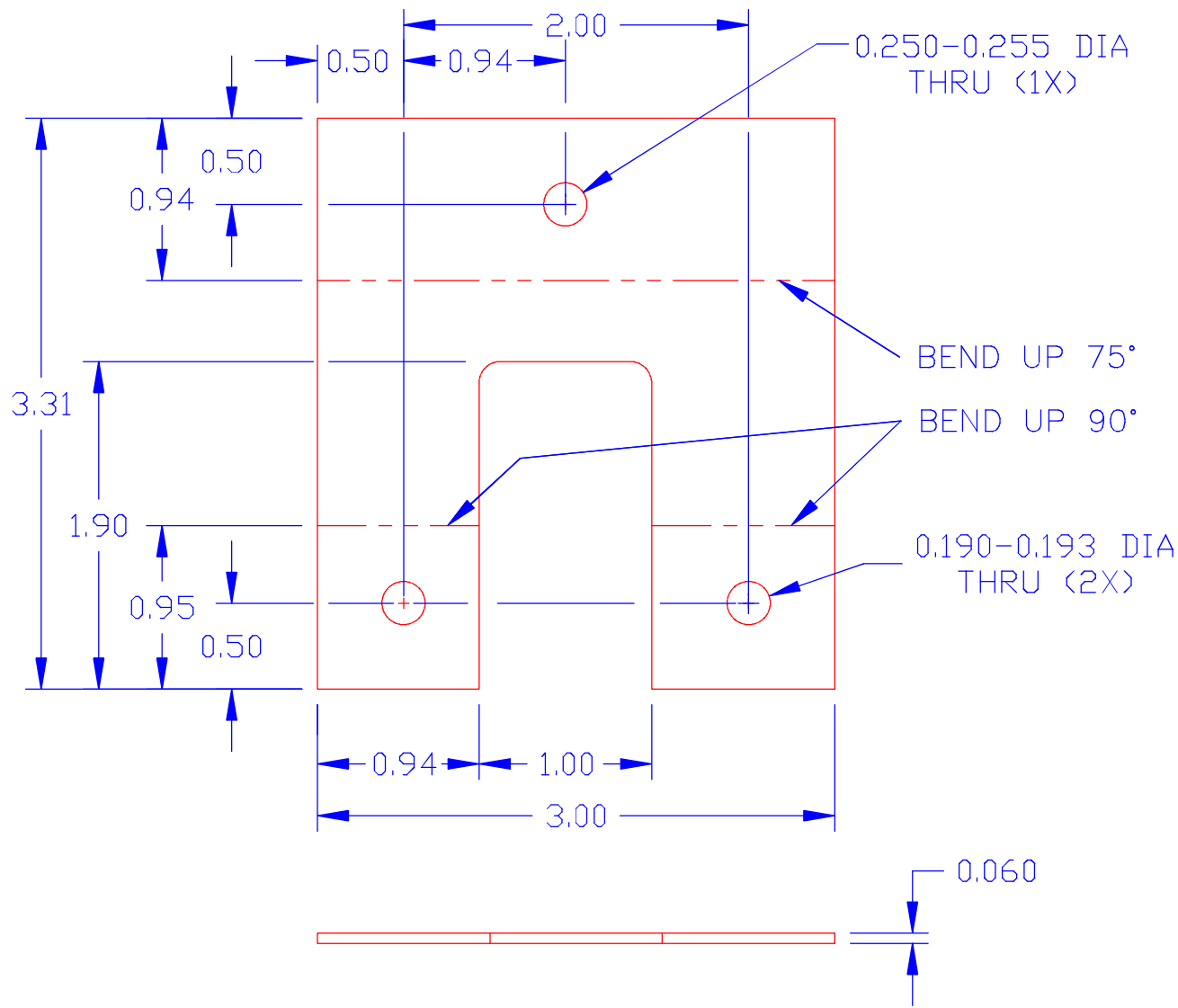

WIPER MOTOR SUPPORT BRACKET FOR MGA

MATERIAL: A366 LOW CARBON CRS

DIMENSIONS ARE IN INCHES

BLANK SIZE: 0.060 (16 GA) X 3 X 3-5/16

TO BE PAINTED AFTER

INSTALLATION OF FASTENERS

DRAWN: BARNEY GAYLORD - 28 AUG 2012

REVISED 11 NOV 2012 - .094 WAS 1.00 (2 PLACES)